



Series 354

SHAWNEE II High-Speed Digital Predetermining Counter



The 354B Directly Replaces 354A.

A compact version of the 334 counter, the ATC 354 is its exact functional duplicate. Packaged in a 72mm² DIN-size housing, it occupies 25% less panel space and costs proportionately less. Modern production and assembly techniques have all but eliminated hand wiring, enhancing the reliability and life expectancy of the 354.

PRODUCT HIGHLIGHTS

COMPUTER-TESTED RELIABILITY

The solid-state 354 is manufactured from a series of computer-tested plug-in circuit boards and assembled virtually without hand wiring. Because it has no moving parts in its logic circuits, its life expectancy is practically unlimited. Even the load relay - the 354's only significant mechanical component - has a life expectancy of 100,000,000 operations (no load), while the optional solid-state switch module has a virtually unlimited life expectancy. As a result, the 354 achieves an overall reliability that surpasses even the high level achieved by previous Shawnee counters.

CYCLE PROGRESS INDICATION

The Shawnee 354 indicating counter provides cycle progress indication on a four-digit display located immediately above the digital setting number wheels. While the non-indicating Model 354 does not provide true cycle progress indication, its *pilot light* signals when the counter is running.

EASY TO SET AT ALL TIMES

The Shawnee counter is easily and accurately set even with work gloves on. Push any of its four toggle levers in any sequence until the number you want appears above it. You can decrease as well as increase each number by pushing the levers *up* or *down*. You can change the setting at any time, even during a cycle.

NOISE IMMUNITY

The 354 does not have to be shielded: its transformer power supply, full-wave bridges, buffered logic and other design characteristics render it immune to the electrical noise that is sometimes encountered in industrial environments thus eliminating false *starts* and *reset* due to voltage spikes.

PLUG-IN AND DUST-TIGHT

All 354 counters feature true plug-in design and are dust-tight from the front of panel.

100% ACCURATE AND BOUNCE-PROOF

The repeat accuracy of the Shawnee 354 is 100% at all rated speeds, even in the presence of contact bounce. The 354 has two selectable levels of bounce suppression: a normal level - which eliminates false counts at speeds up to 500 per second with reed switch inputs, and 5,000 per second with DC voltage pulses; and a high level, for speeds up to 80 per second with high-bounce contact closures (relays, precision switches, etc.).

HOUSING, IT OCCUPIES 40% LESS

Packaged in a 72 mm² DIN-size housing, the 354 occupies 40% less panel space than previous IC counters. Modern production and assembly techniques have substantially reduced manufacturing costs resulting in a 45% cost saving.

CONTROL VERSATILITY

The 354 operates either as a repeat cycle pulse generator or in single-cycle interval or delayed mode: you choose the kind of control action you want by installing jumpers on the terminal block. It also provides a choice of control output, a standard plug-in SPDT relay or an optional SPST solid-state switch module...plus an independent and separate DC output signal at Terminal 6.

APPROVALS

See Agency Listing on inside back cover of catalog.

See next page for additional product features.

OPERATION

The Shawnee 354 operates on a digital logic circuit with three main elements: *input circuits* which allow it to count various types of DC pulses; a *read-only-memory (ROM)* whose output is set by the counter's digital setting number wheels; and a *comparator* that continuously examines the outputs of the input circuit and ROM.

When the *start* (ready/reset) signal is **on**, the input circuit begins to count incoming pulses, feeding the total count continuously to the comparator. When input circuit output exactly equals ROM output, the 354 counts out. At that instant, the input circuit automatically turns itself **off** even if the *start* signal remains **on**; it is therefore not necessary to turn off the pulses externally.

At the same instant, the 354 provides one of three load control actions depending on how it is wired (see Typical Applications).

When the 354 is wired for interval operation, the counter's output device (either the standard SPDT relay or the optional SPST switch module) is energized from the start to the end of the count cycle; so is the DC output at terminal 6.

When the 354 is wired for delayed control, the output device is energized at the end of the cycle and remains **on** until the counter is reset; so is the DC output.

When the 354 is wired as a repeat cycle pulse generator, the output device and the DC signal are both **off** until the end of the count cycle, at which time they are both **on** for about 80 ms. From the instant that the output pulse comes on, the 354 stops counting for 500 μ s while it resets; it automatically begins a new cycle and starts counting pulses again immediately after reset.

The duration of the pulse generated by the 354 can be easily lengthened or shortened by wiring a capacitor or resistor across terminals 12 and 14 (see Typical Applications).

WIRING

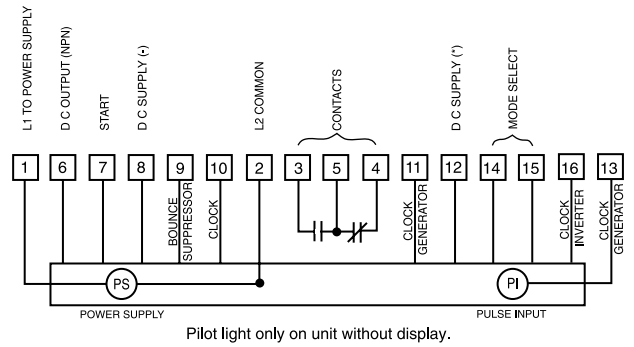

TERMINAL WIRING

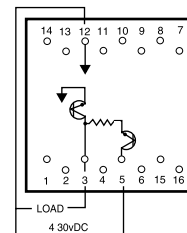
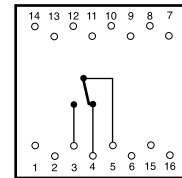

SOLID STATE OUTPUT MODULE

Before starting your design, read the safety statement on the inside back cover of the ATC catalog.

TYPICAL APPLICATIONS

The Shawnee 354 has a readily accessible 16-point terminal which allows its use with a variety of *start* circuits and *input* pulses and to *program* it for the desired *load* action. To wire the 354 so as to suit a particular application is a relatively simple matter that is easily accomplished by selecting one of the examples in each of the following four steps. Combine the four examples for your wiring diagram.

STEP 1 - START CIRCUITS

The 354 accommodates three types of *start* signals. To wire the counter properly to your *start* signal, first determine which of the three types applies, then consult the appropriate wiring diagram. Note that AC line connections are *always* made to Terminals 1 and 2.

A. ISOLATED CONTACT (sustained *start* signal) The external dry *start* switch must be closed throughout the count cycle. The 354 is ready to count whenever the switch is closed; it resets when the switch is opened.

ISOLATED CONTACT START— SUSTAINED (EXTERNAL START SWITCH)

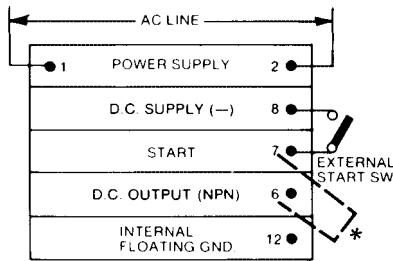

*Jumper for momentary start in interval mode.

B. DC VOLTAGE (sustained *start* signal) The *start* voltage must be **on** throughout the count cycle. The 354 is ready to count whenever the voltage reaches +4.5 or -3V DC; it resets when the voltage drops to +1 or -1V DC.

DC VOLTAGE START (SUSTAINED START)

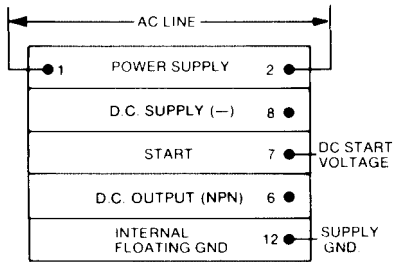

C. NEGATIVE DC VOLTAGE (momentary* or sustained *start* signal) The *start* signal may be momentary or sustained. The 354 is ready to count whenever the *start* voltage reaches -3V DC. It resets at the end of the cycle, when the *start* voltage is momentary; or as soon after count-out as the *start* voltage drops between -1 and 0V DC, when the *start* signal is sustained.

NEGATIVE DC VOLTAGE (MOMENTARY* OR SUSTAINED START)

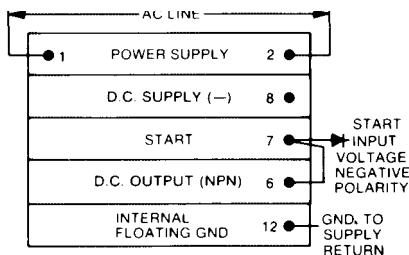

STEP 2 - PROGRAMMING

The 354 can be used for delayed or interval control or as a repeat-cycle pulse generator. Here again, decide which mode you want, then consult the appropriate wiring diagram. Note that the 354 counts on the *break* of a contact or decrease of a voltage signal when an external jumper is installed between Terminals 12 and 16, as shown in the diagrams in this step. It can also be programmed to count on *make* simply by leaving the jumper **off**.

A. DELAYED MODE. The SPDT relay provides one delayed closing and one delayed opening circuit, and the 354 generates a DC signal at Terminal 6 at the end of the cycle.

DELAYED MODE

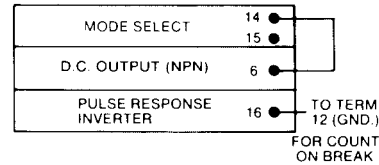

B. INTERVAL MODE. The SPDT relay provides one interval opening and one interval closing circuit, and the 354 provides a -24V DC signal at Terminal 6 during the cycle.

INTERVAL MODE

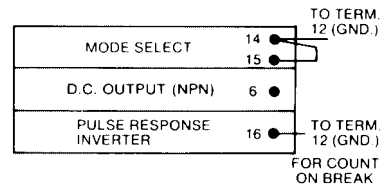

C. REPEAT CYCLE PULSE GENERATOR. In this mode, the 354 generates an output of 80 ms (± 20 ms) at the end of the count cycle; the length of the output pulse can be adjusted as follows:

To *shorten* the pulse, install a fixed or variable resistor between Terminals 12 and 14, sizing it according to this formula:

$$\frac{2.2T - 26.4}{80-T} = R$$

Where: T = time in ms ($\pm 25\%$)

R = resistance in megohms

To *lengthen* the pulse, install a capacitor between Terminals 12 and 14 (if a polarized capacitor, install + to 12, -to 14) and size it according to the formula:

$$\frac{T - 0.08}{1.6} = C$$

Where: T = time in sec ($\pm 25\%$)

C = capacitance in microfarads.

REPEAT CYCLE PULSE GENERATOR

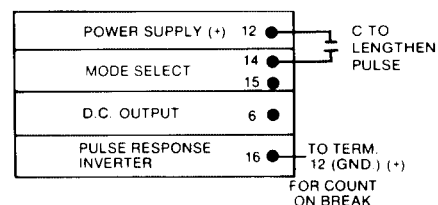

STEP 3 - PULSE INPUTS

The 354 can count from low or high-speed contacts or, by virtue of its built-in pulse shaper, from DC voltage pulses of positive or negative polarity. Choose the wiring diagram that suits your application.

A. LOW-SPEED CONTACTS. The 354 counts input pulses from precision switches, relays, limit switches, etc., at speeds up to 80/sec.

LOW SPEED CONTACTS

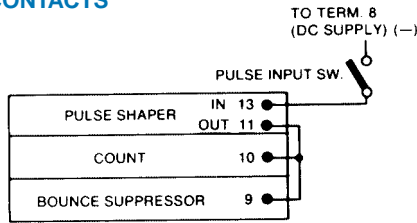

B. HIGH-SPEED CONTACTS. Input pulses from low-bounce contacts, reed switches, etc., can be counted at speeds up to 500/sec. In this circuit *only*, the 354 counts on the *break* of the pulse switch as received; to count on *make*, install a jumper between Terminals 12 and 16; this is the *reverse* of the situation that applies to all other 354 circuits.

HIGH SPEED CONTACTS

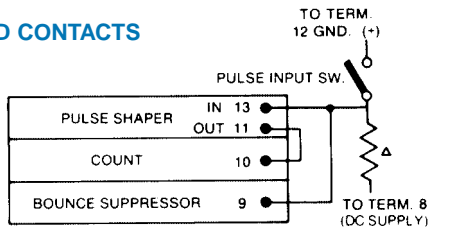

NOTE: With this circuit, to count on break, remove 12-16 jumper, shown in Step 2.

▲ Recommended Value = 33K 1/2 W 10%

C. DC VOLTAGE PULSES. In this circuit, the 354 counts when the voltage decreases from above +4.5V to below +1V, or from above -3V to below -1V, with a jumper installed between Terminals 12 and 16 as shown in Section 2; to reverse the action, simply remove the jumper.

COUNT DC VOLTAGE PULSES

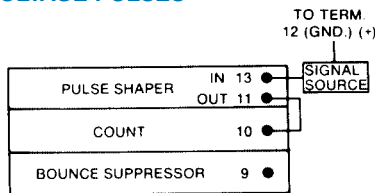

STEP 4 - LOAD ACTION

The load action of the 354 depends on the choice of *start* circuit and *programming* mode. Loads are always wired to the 354 in the following manner:

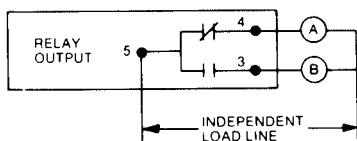

If the 354 is equipped with the optional SPST solid-state switch module, its contacts are always available at Terminals 3 and 5, and its load action is the same as for Load B in the drawings right.

A. DELAYED MODE. The load action in this mode is always the same regardless of the kind of *start* circuit selected in Step 1; but the *start* signal must remain **on** during the entire count cycle, as the counter resets when the *start* signal is removed.

DELAYED MODE

	Before Start	During Cycle	End of Cycle
START SW	Gray	Blue	Gray
LOAD A	Gray	Blue	Gray
LOAD B	Gray	Blue	Gray

RESETS TO BEFORE START

B. INTERVAL MODE WITH SUSTAINED START. In this mode also, the counter resets when the *start* signal is removed.

INTERVAL-SUSTAINED START

	Before Start	During Cycle	End of Cycle
START SW	Gray	Blue	Gray
LOAD A	Gray	Blue	Gray
LOAD B	Gray	Blue	Gray

RESETS TO BEFORE START

C. INTERVAL MODE WITH MOMENTARY START. Because of the 354's electronic latch capability, it can provide interval control with a momentary negative DC voltage *start* signal, in which event the 354 resets at the end of cycle. But the counter will also operate with a sustained *start* signal, in which case it resets when the *start* signal goes off, as described above.

INTERVAL—MOMENTARY OR SUSTAINED START

	Before Start	During Cycle	End of Cycle
START SW	Gray	Blue	Gray
LOAD A	Gray	Blue	Gray
LOAD B	Gray	Blue	Gray

D. REPEAT CYCLE PULSE GENERATOR. When this mode is selected, the *start* signal must remain **on** continuously. The 354 generates an output pulse at the end of each count cycle, then resets and repeats automatically. At least 500 μs is required for resetting, between the last count of one cycle and the first count of the next. Count pulses can be of unequal length -- long and short as shown in the diagram -- provided that they meet the minimum requirements listed in the SPECIFICATIONS.

REPEAT CYCLE PULSE GENERATOR

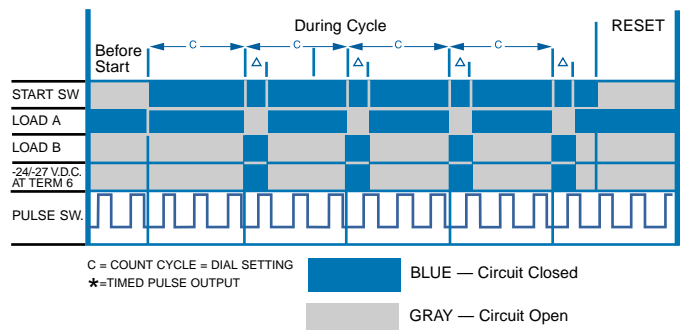

SPECIFICATIONS

MODELS

Both indicating and non-indicating models of the 354 are available. See ordering code.

CYCLE PROGRESS INDICATOR (indicating model only):

4 digit, 0.3 inch, high intensity, blue display.

RANGE

1 to 9999 counts or 10 to 99,990, presettable in 10 count increments.

PULSE INPUTS

ISOLATED CONTACT INPUT (Dry)

MIN. OPEN RESISTANCE: 1 megohm

MAX. CLOSED RESISTANCE: 20K ohms.

SWITCH REQUIREMENTS: 10mA, 30V.

COUNT RATE AND BOUNCE IMMUNITY

With normal bounce immunity--for Reed Switches (Terminal 9 jumpered to 13):

MAX. COUNT RATE: 500/sec.

MIN. CLOSED TIME: 100 μ s.

MIN. OPEN TIME: 1 ms.

MAX. OPEN TIME FOR ANY SINGLE BOUNCE: 0.3 ms.

With maximum bounce immunity--for

Precision Switches (Terminal 9 jumpered to 10 and 11):

MAX. COUNT RATE: 80/sec.

MIN. CLOSED TIME: 30 μ s.

MIN. OPEN TIME: 6 ms.

MAX. OPEN TIME FOR ANY SINGLE BOUNCE: 2.5 ms.

VOLTAGE INPUTS

VOLTAGE REQUIREMENTS:

POSITIVE POLARITY: **On** at 4.5V min.

Off at 1.0V max.

NEGATIVE POLARITY: **On** at 3.0V min.

Off at 1.0V max.

MAX. CONTINUOUS INPUT: 40V.

RIPPLE VOLTAGE:

Must not go below min. req.

INPUT IMPEDANCE: 5K ohms

MIN. ON TIME: 60 μ s.

MIN. OFF TIME: 100 μ s.

COUNT RATE: 5K Hz max.

RISE AND FALL TIME REQ: none.

START (READY/RESET) SIGNAL

VOLTAGE REQUIREMENTS:

POSITIVE POLARITY: *ready* at 4.5V min.

reset at 1.0V max.

NEGATIVE POLARITY: *ready* at 3.0V min.

reset at 1.0V max.

MAX. CONTINUOUS INPUT: 40V

RIPPLE VOLTAGE:

must not go below min. req.

INPUT IMPEDANCE: 5K ohms

READY-TO-COUNT TIME: 0.5 ms max

(after application of voltage to Terminal 7)

RESET TIME

CIRCUIT RESET: 1 ms max.

RELAY DROP-OUT: 20 ms max.

START SWITCH REQUIREMENTS

(isolated contact)

SWITCH RATING: 10mA, 30V

MIN. OPEN RESISTANCE: 1 megohm.

MAX. CLOSED RESISTANCE: 20K ohms

LATCHING MODE OPERATION

(interval only)

MIN. DURATION START SIGNAL: 50 μ s.

MAX. DURATION START SIGNAL

continuous

RESET: when signal is removed after count-out.

DELAYED MODE

RELAY OPERATE TIME

(after coincidence): 20ms. max.

RELAY RELEASE TIME: 20ms max.

INTERVAL MODE

RELAY OPERATE TIME: 15ms max.

RELAY RELEASE TIME

(after coincidence): 25 ms max.

AUTOMATIC RECYCLE MODE

PULSE ON TIME (with relay):

80 ms, \pm 20 ms

(may be shortened or lengthened by installing a resistor or capacitor, respectively, across Terminals 12 and 14; see Application section for details)

RECYCLE TIME AT RESET:

500 μ s. max.

LOAD RELAY

LIFE: 100,000,000 operations (no load)

CONTACT RATING: 5 A at 120VAC

2 A at 240V AC

0.1 A at 125 V DC

SOLID-STATE SWITCH MODULE (Optional)

Switches external DC voltage supply of positive polarity, 4 to 30V, 50 mA max.;

factory-wired to Terminals 3 and 5 (detailed description of operation in Installation Instruction IN-354)

DC OUTPUT (Terminal 6)

VOLTAGE: **on--** -24V \pm 10%.

off-- -1V or less

CURRENT: *with relay* --5mA max.

without relay --40mA max.

IMPEDANCE: **on--** 10 ohms max.

off--10K ohms.

DC POWER SUPPLY OUTPUT (Terminal 8)

VOLTAGE: 24V \pm 10%.

CURRENT: 40mA max.

POWER REQUIREMENTS:

120V: 95 to 132V, 50/60 Hz

inrush -- 0.4A

running -- 0.04A.

240V: 190 to 264V, 50/60 Hz

inrush -- 0.2A

running -- 0.02A.

TEMPERATURE RATING

0 to 60°C (32° to 140°F.)

WEIGHT

NET: 1 lb., 7 oz.

SHIPPING: 2lbs.

MOUNTING ACCESSORIES

STANDARD: Hardware is provided to mount counter so that it is dust-tight from front of panel.

OPTIONAL: Surface mounting with front-facing terminals.

(See Accessory section of catalog)

NEMA 12 molded case (1 counter)

DIMENSIONS:

INCHES
MILLIMETERS

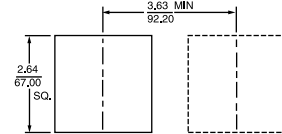
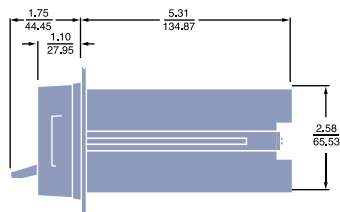
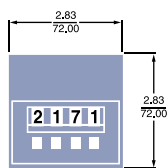

PANEL CUTOUT
SHOWING DISTANCE BETWEEN
ADJACENT CUTOUTS.

Before starting your design, read the safety statement on the inside back cover of the ATC catalog.

SERIES 354 HIGH-SPEED DIGITAL PREDETERMINING COUNTER

ORDERING CODE

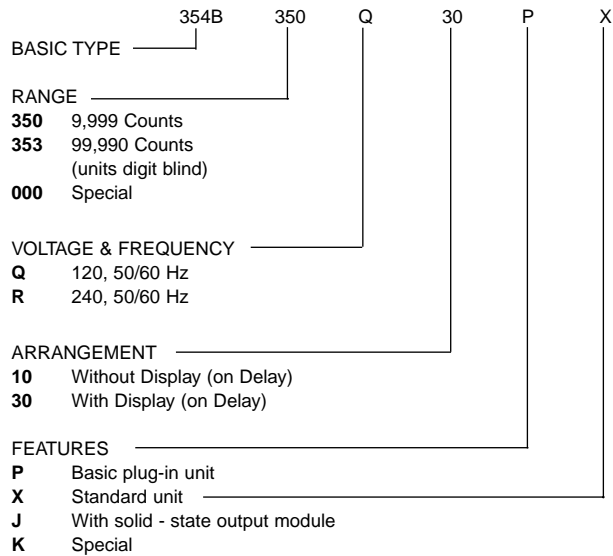

ACCESSORIES

- 0353-260-27-00** Surface mounting bracket kit
- 0305-265-61-70** Retrofit kit

For prices and further information, consult factory.

The 354B Directly Replaces 354A.