

A Dial-Adjustable TDR with cycle progress indication, the ATC 322 can also be used as a low-cost automatic reset timer for a wide range of interval, delay and pulse timing functions, in either ON-delay or OFF-delay operation.

PRICE/PERFORMANCE VALUE: Although it is priced like a TDR, the 322 provides the versatile timing functions and features of much more expensive automatic reset timers.

INSTANTANEOUS AND DELAYED LOAD SWITCHES: Because the standard 322 includes an instantaneous switch as well as two delayed switches, it can be used in the On-Delay mode for interval and/or delayed control, with either a momentary or sustained start signal. All three switches are mounted on a sliding deck which facilitates replacement and maintenance.

SURFACE OR FLUSH MOUNT: The 322 is provided with hardware for surface mounting or, if desired, flush mounting through a single 15/16" OD cutout in a 1/8" panel.

CYCLE PROGRESS INDICATION: A pointer in the dial knob rotates during the cycle, continuously showing the time remaining until time-out.

OPERATION

The 322 is a synchronous motor-driven timer with an electrically-operated clutch equipped either for On-Delay or Off-Delay operation.

ON-DELAY: When power is applied (start signal sustained on), the clutch engages, the motor begins to drive a cam toward its zero position, and the instantaneous switch transfers from one set of contacts to the other. At the end of the timed period, the cam trips one of the delayed switches, but the motor continues to run. A brief time later (about 2-1/2% to 5% of full scale), the cam trips the second delayed switch, stopping the motor but leaving the clutch engaged. The 322 resets when power is removed from the clutch.

OFF-DELAY: Timing begins when power is removed (start signal off) from the spring-loaded, normally-engaged clutch. The timer resets when power is restored to the clutch, thus disengaging it and transferring the instantaneous switch from one set of contacts to the other. Action of the delayed contacts is the same as with the On-Delay timer. A power outage stops the motor but does not reset the Off-Delay 322; the timer completes the interrupted cycle when power is restored.

WIRING

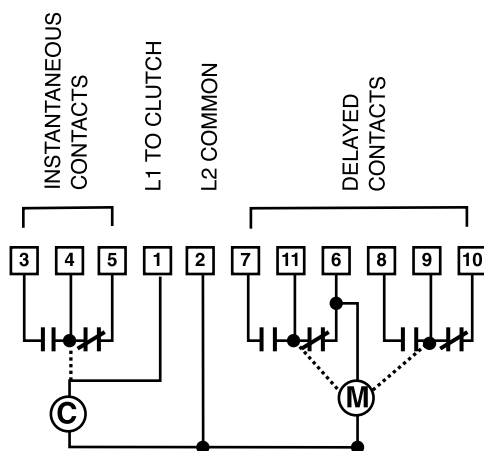

Motor-Driven Cycle Progress Timer

SPECIFICATIONS

MODEL	Choice of ON-Delay or OFF-Delay operation (not field-convertible)
RANGES	11 standard ranges, from 5 SEC to 5 HRS at 60Hz (6 SEC to 6 HRS at 50 Hz)
REPEAT ACCURACY	- 2% of dial range.
RESET TIME	150 ms.
MIN. SETTING	5% of dial range.
LIFE EXPECTANCY	MECHANICAL: 2,500,000 cycles (average) CONTACTS: 2,500,000 operations under resistive or inductive load of 1A
TIMING MODES	SINGLE CYCLE: interval, delay or pulse.
LOAD SWITCHES	INSTANTANEOUS: one, SPDT, precision type. DELAYED: two, SPDT, precision type. CONTACT RATINGS (non-inductive): 10 A at 120 VAC 5 A at 240V A C
TERMINALS	11-point terminal block on side of housing; all terminals accept .250" push-on connectors. Terminals 1, 2, 4, 9 and 11 are split connectors for use with either one .250" or two .110" push-on connectors.
POWER REQUIREMENTS	120 or 240V, 50 or 60 Hz. ($\pm 10\%$, - 15%) Running Current 121 mA (14.5 VA) at 120V Inrush Current 157 mA (18.9 VA) at 120V
TEMPERATURE RATING	32° to 120°F (0° to 50°C)
WEIGHT NET:	1 lb. 8 oz
SHIPPING:	2 lbs.

RANGE - 60HZ- 120 VAC

5 SEC	114
10 SEC	003
20 SEC	005
40 SEC	115
60 SEC	007
150 SEC	009
5 MIN	012
10 MIN	014
40 MIN	056
60 MIN	017
5 HR	113

RANGE - 50 HZ - 120 VAC

6 SEC	101
12 SEC	116
24 SEC	117
48 SEC	118
72 SEC	073
180 SEC	119
6 MIN	029
12 MIN	047
48 MIN	058
72 MIN	061
6 HR	030
Special	000

**VOLTAGE
FREQUENCY**

120/60	A
240/60	B

120/50	C
240/50	D
Special	K

MODEL NUMBER

MODEL NUMBER	322B				2	
RANGE						
VOLTAGE & FREQUENCY						
ARRANGEMENTS						
ON-DELAY (reset on power interruption)						1
OFF-DELAY (non-reset on power interruption)						2
Special						0
SWITCH DIFFERENTIAL						
2-1/2% - 5% of dial range						2
FEATURES						
STANDARD surface mounting unit, clutch contact						CS
SPECIAL						CK

DIMENSIONS (INCHES/MILLIMETERS)

SURFACE MOUNTING OF TIMER

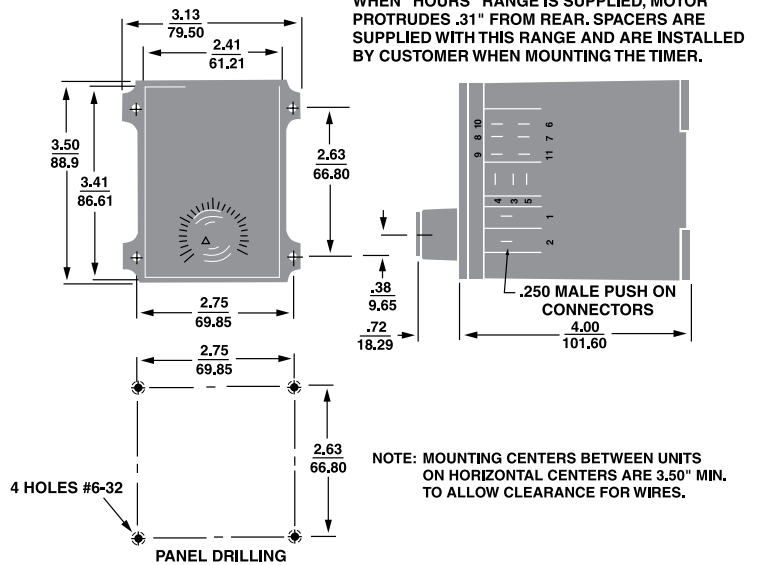

FLUSH MOUNTING OF TIMER

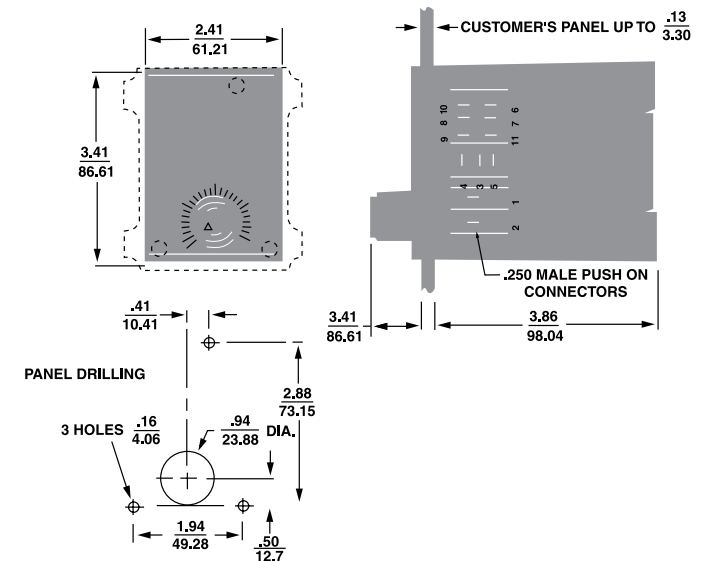

SWITCH	CONTACTS	ON DELAY		
		Timing Sequence**		
		Before Start	During Cycle *	End of Cycle *
Instantaneous	4-3	BLACK	GRAY	GRAY
	4-5	BLACK	GRAY	GRAY
Delayed (D ₂)	11-6	BLACK	GRAY	GRAY
	11-7	BLACK	GRAY	GRAY
Delayed (D ₁)	9-10	BLACK	GRAY	GRAY
	9-8	BLACK	GRAY	GRAY

BLACK
Circuit Closed

GRAY
Circuit Open

* D₂ trips approximately 2-1/2% of range after end of cycle.

** Assumes a sustained closed start signal (i.e. longer than the dial set time).

SWITCH	CONTACTS	OFF DELAY		
		Timing Sequence**		
		Before Start	During Cycle *	End of Cycle *
Instantaneous	4-3	BLACK	GRAY	GRAY
	4-5	BLACK	GRAY	GRAY
Delayed (D ₂)	11-6	BLACK	GRAY	GRAY
	11-7	BLACK	GRAY	GRAY
Delayed (D ₁)	9-10	BLACK	GRAY	GRAY
	9-8	BLACK	GRAY	GRAY

* D₂ trips approximately 2-1/2% to 5% of range after end of cycle.

** Assumes a sustained closed start signal (i.e. longer than the dial set time).