



Shawnee II Digital Reset Timer



ISE 10100 Royalton Rd., Cleveland, OH 44133 USA
 Phone: (440) 237-3200 Fax: (440) 237-1744 iseinc.com

MODEL NUMBER

MODEL NUMBER	355C			30	P	
RANGE						
999.9 SEC	346					
999.9 MIN	347					
99.99 SEC	351					
99.99 MIN	352					
Special	000					
VOLTAGE & FREQUENCY						
120/60			A			
240/60			B			
120/50			C			
240/50			D			
ARRANGEMENT						
With Display (On Delay)				30		
FEATURES						
Basic plug-in unit					P	
Standard unit						X
Special						K

ACCESSORIES:

Surface mounting bracket kit	353-260-27-00
Retrofit kit	305-265-61-70

A compact version of the 335 Timer, the ATC 355 is its exact functional duplicate, packaged in a 72mm² DIN-Size housing, it occupies 40% less panel space and costs proportionately less. Modern production and assembly techniques have all but eliminated hand wiring, enhancing the reliability and life expectancy of the 355.

COMPUTER TESTED RELIABILITY: The Solid-State 355 is manufactured from a series of computer-tested plug-in circuit boards and assembled virtually without hand wiring. Because it has no moving parts in its logic circuits, its life expectancy is practically unlimited. Even the load relay — the 355's only significant mechanical component — has a life expectancy of 100,000,000 operations (no load). As a result, the 355 achieves an overall reliability that surpasses even the high level achieved by previous Shawnee timers.

CYCLE PROGRESS INDICATION: The Shawnee indicating timer provides cycle progress indication on a four-digit display located immediately above the digital setting number wheels.

PLUG-IN AND DUST-TIGHT: All 355 timers feature true plug-in design and can be replaced in seconds without disturbing the housing or disconnecting the wiring. The dial assembly is gasketed so that the timer body is dust-tight from the front of panel.

WIDE RANGE: Each Shawnee 355 timer covers the overall span of 0.01 SEC to 999.9 MIN in two field-convertible ranges. The 355 indicating timer also offers two additional field-convertible ranges of 0.1-999.9 SEC or MIN

EASY TO SET AT ALL TIMES: The Shawnee timer is easily and accurately set even with work gloves on. Push any of its four toggle levers in any sequence until the number you want appears above it. You can decrease as well as increase each number by pushing the levers up or down. You can change the setting at any time, even during a cycle.

SAVE 40% IN PANEL SPACE AND COST: Packaged in a 72mm² DIN-size housing, the 355 occupies 40% less panel space than previous IC timers. Modern production and assembly techniques have substantially reduced manufacturing costs and resulted in a 45% cost saving.

OUTSTANDING REPEAT ACCURACY: Unsurpassed among industrial timers regardless of cost, the Shawnee has a repeat accuracy of ±10 milliseconds on any setting within its overall range of 999.9 MIN, even in the face of wide swings in temperature or voltage and regardless of the amount of reset time between cycles.

NOISE IMMUNITY: The 355 does not have to be shielded: its transformer power supply, full-wave bridges, buffered logic and other design characteristics render it immune to the electrical noise that is encountered in typical industrial environments

The 355C Directly
 Replaces 355B & 355A
 Functional Replacement
 for the 335 Timer

SPECIFICATIONS

RANGES	0.01 - 99.99 SEC	
	0.01 - 99.99 MIN	
	0.1 - 999.9 SEC	
	0.1 - 999.9 MIN	
Four field-convertible ranges		
TIMING MODES	Single Cycle	interval or delay
	Repeat Cycle	pulse (fixed at approx. 50 mSEC)
CYCLE PROGRESS INDICATOR	4 digit, 0.3 inch, high intensity, blue display	
REPEAT ACCURACY	±0.01 SEC on all ranges	
RESET TIME	75 milliseconds	
MINIMUM SETTING	99.99 SEC of MIN ranges: 0.01 SEC or MIN, respectively 999.9 SEC or MIN ranges: 0.1 SEC or MIN, respectively	
LOAD RELAYS	Number	two, one instantaneous and one delayed; both plug-in DPDT
	Operate Time	20 mSEC, max.
	Release Time	instantaneous — 20 mSEC, max. delayed — 75 mSEC, max.
	Contact Rating	5 A at 120 VAC, Life 100 million operations (no load)
TEMPERATURE RATING	32° to 140°F (0 to 60°C)	
POWER REQUIREMENTS	120V	95-132V at 50 or 60 Hz inrush — 0.2 A running — 0.04 A
	240V	190-264V AT 50 OR 60 Hz inrush — 0.1 A running — 0.02 A
	Clock Input	
	Voltage	95-132V rms (120V Model) 190-264V rms (240V Model)
	Current	20 mA max.
	Frequency	0 to 1000 Hz (sinusoidal)
TERMINALS	16 screw terminals accessible at rear; integral wiring diagram on housing	
HOUSING	Plug-in design; completely gasketed, dust-tight when panel-mounted	
MOUNTING ACCESSORIES See Accessory section of catalog	Standard	Hardware is provided to mount timer so that it is dust-tight from front of panel
	Optional	Surface mounting without and with front-facing terminals
	NEMA 12 case (1 timer)	
WEIGHT	NET: 1 lb., 7 oz. SHIPPING: 2 lbs	

OPERATION

The Shawnee 355 operates on a digital logic circuit with three main elements: a clock which uses utility line frequency of 50 or 60 Hz as its time base; a read-only-memory (ROM) whose output is set by the timer's digital setting number wheels; and a comparator that continuously examines the outputs of the clock and ROM.

When power is applied (start signal on), two things happen simultaneously; the instantaneous DPDT relay is energized transferring both sets of contact, and the clock circuit begins to count each cycle of the utility line frequency. Translating this count into hundredths of a second, the clock accumulates it and feeds it continuously to the comparator. When clock output exactly equals the output of the ROM, the comparator causes the 355C to time out.

At this point, (1) the DPDT delay relay is energized, immediately transferring both sets of contacts and (2) the clock turns itself off automatically. Since the clock stops counting even if the start signal remains on, it is not necessary to tie up one of the 355C's delayed contacts to do this job.

To reset the Shawnee 355, power must be removed from terminal 1 (L1) for 75 milliseconds or more. The 355 operates in the On-Delay mode only, always resetting whenever there is a power outage and starting a new cycle when power is restored.

CYCLE PROGRESS INDICATION: When the timer is in the reset condition, the LED display is blank. During the timing cycle, the display counts up from zero, thus always indicating the amount of time that has elapsed since the start of cycle. At time-out, the display shows total elapsed time and exactly equals the numbers on the digital setting wheels.

		Switching Sequence: Assumes a sustained closed start signal (i.e. longer than the setting on the digital display.)		
RELAY	CONTACTS	Before Start	During Timing	End of Cycle
Instantaneous	14-9/6-8	■	■	■
	14-10/6-7	■	■	■
Delayed	11-12/4-5	■	■	■
	11-13/4-3	■	■	■

BLACK-Circuit Closed
 GRAY-Circuit Open

TYPICAL INSTALLATIONS

- POWER SUPPLY
- CLOCK
- INDEPENDENT LOADS
- DEPENDENT LOADS
- MOMENTARY STARTING CONTACT
- SUSTAINED STARTING CONTACT
- LOAD ENERGIZED
- LOAD DE-ENERGIZED

All timers shown in "before start" position. Diagrams shown with power off unless otherwise marked. Maximum load current through any load carrying contact is 5 amperes. Pilot lights leads are brought out to terminal block. Pilot light can be wired to show practically any desired function timer energized, cycle running instantaneous or delayed switch closed, etc.

- DELAYED CONTACTS
Contacts transfer simultaneously when unit "times out" and all digits are zero.

- INSTANTANEOUS CONTACTS
Contacts are transferred when power supply is energized, transferred back as shown when de-energized.

DIMENSIONS (INCHES)

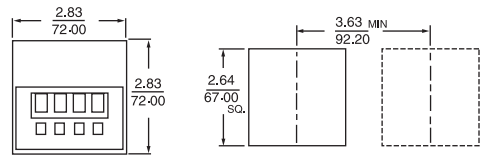

PANEL CUTOUT SHOWING DISTANCE BETWEEN ADJACENT CUTOUTS.

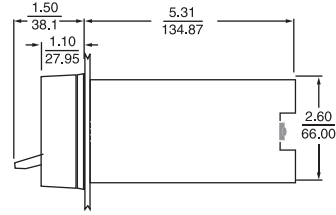

SUSTAINED START

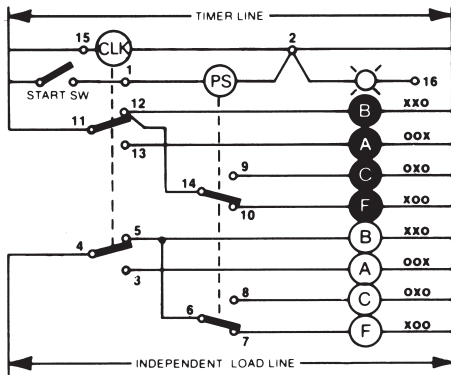

MOMENTARY START

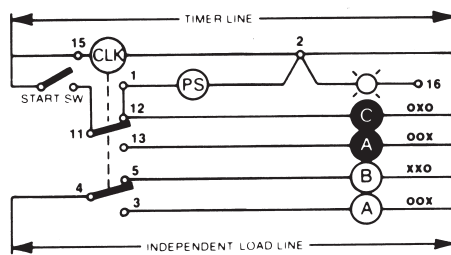
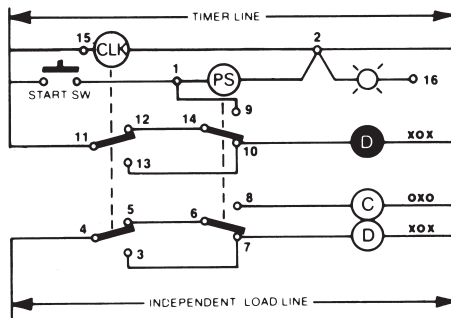

WIRING

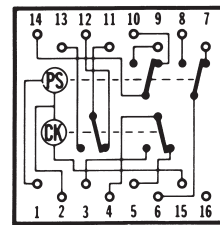
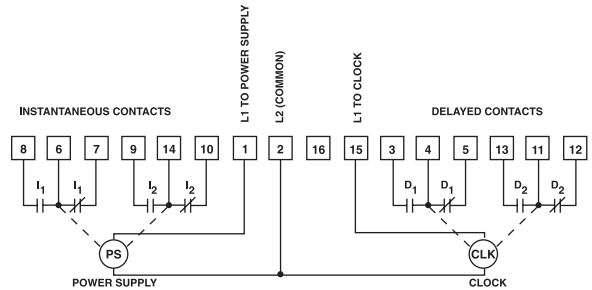

TERMINAL WIRING



ISE, Inc.
Serving Industry Since 1946
ISE 10100 Royalton Rd., Cleveland, OH 44133 USA
Phone: (440) 237-3200 Fax: (440) 237-1744 iseinc.com