

## Digital Stroboscope/Tachometer Model DT-721

## Instruction Manual

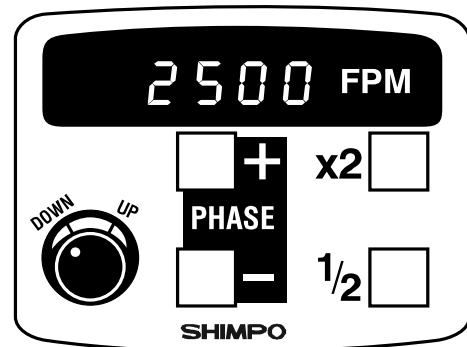

### Features



### Operational Precautions

- Do not operate or store instrument in the following places:
  - Explosive areas
  - Near water, oil, dust or chemicals
  - Areas where temperature is above 104°F (40°C).
- Do not look at the emitted light for long periods of time; it can be harmful to the eyes.
- Do not disassemble or repair unit while in operation.
- To mount the strobe on a tripod (or any other mounting surface), use screw 1/4 - 20unc, length 8mm or shorter, for the tripod screw hole on the bottom.

#### Setter

The setter changes the flashing rate. Turn CW to increase the rate, turn CCW to decrease rate.

#### x2 Switch

Pressing "x2" will double and display the flashing rate.

#### 1/2 Switch

Pressing the "1/2" will divide flashing rate by two and display it.

#### Plus (+) Switch

When object appears to be standing still, pressing "+" will give the illusion that the object is moving towards the opposite direction of rotation. This action increases the rate slightly (phase shift) and is used to place the object in desired position.

#### Minus (-) Switch

When object appears to be standing still, pressing "-" will give the illusion that the object is moving towards the rotating direction. This action decreases the rate slightly (phase shift) and is used for the same reason as above.

#### Input and Output Connectors

Phonejack (3.5 mm)

Tip: Signal

Sleeve: GND

Power switch with lock option

Power cord

## Operation

### Internal Triggering

1. Firmly plug power cord into a 100VAC (Japan), 120 VAC (US) or 230 VAC (Europe) single phase.
2. Aim light beam at object under observation. The best distance between the strobe and moving object is approximately 2 ft.
3. Measure rpm by turning setter. Turn setter to adjust the flashing rate to the rotational speed of the object. To reach the desired rate faster, use the 1/2 or x2 switches.

### External Triggering

1. Connect wires according to connector pin designation:  
Tip: signal  
Sleeve: Gnd
2. Plug power cord into a 100VAC (Japan), 120 VAC (US) or 230 VAC (Europe). Pull power trigger switch and lock it. When the ext. phone jack is inserted in unit, the strobe automatically switches from the internal mode to the external.
3. The strobe will flash every time the sensor puts out a pulse. See specifications table for input signal requirements.
4. If the input signal frequency exceeds upper or lower limits, the alarm mark will be displayed and the strobe will stop flashing.

### Synchronous Output Signal

The Synchronous output signal appears on the tip of the output phonejack.

See table for more information.

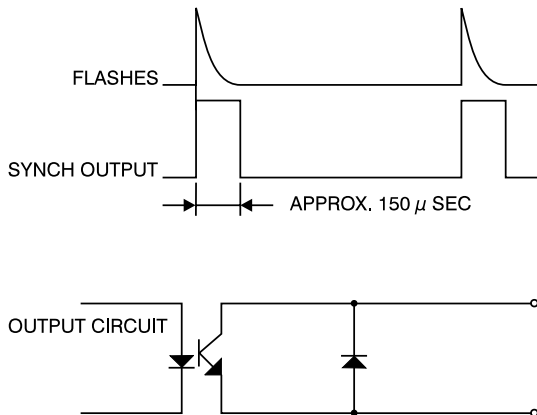

## Memory

When the strobe is turned off and on again at a later time, it will start to flash at the previous displayed rate regardless if the setter has been moved or not.

## True RPM

All strobes give the illusion of stopped motion when flashing in submultiples of the true speed.

To obtain the correct rpm, turn knob from highest fpm downward. When the first single image appears, read the true rpm. To verify it, press "1/2". A single image will appear again.

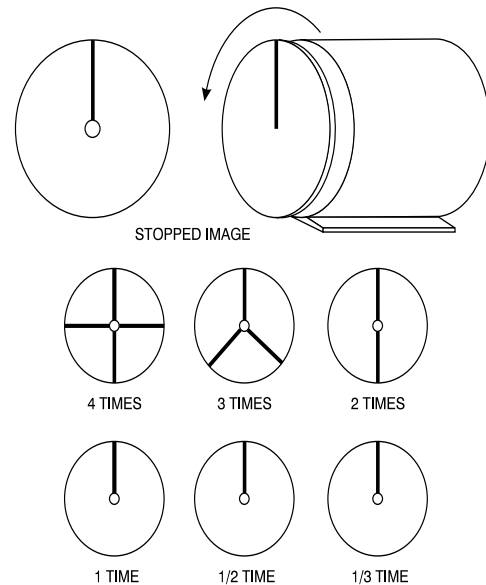

Rotation of shaft (rpm)	Number of flashes (rpm)	Flashes/rpm shaft	Number of stopped images
at 1,500 rpm	6,000	4 times	4
	4,500	3 times	3
	3,000	2 times	2
	1,500	1 times	1
	750	1/2 times	1
	500	1/3 times	1

## Specifications

<b>MODEL</b>	<b>DT- 721(AC)</b>
<b>FLASHING RANGE</b>	40 — 12,500 FPM (Flashes Per Minute)
<b>ACCURACY</b>	±0.02% of reading
<b>RESOLUTION</b>	0.1 , 40.0 – 4,999.9 FPM 0.2 , 5,000.0 – 7,999.8 FPM 0.5 , 8,000.0 – 9,999.5 FPM 1 , 10,000 – 12,500 FPM
<b>DISPLAY</b>	5-Digit LED, 0.3" (8 mm) height
<b>RATE</b>	Divide by 2, Multiply by 2
<b>UPDATE TIME</b>	Ext. mode: varies with flashing rate
<b>OPERATING TIME</b>	Continuous
<b>FLASH TUBE POWER/LIFE</b>	Xenon, 10 W, 100 million flashes
<b>FLASH DURATION</b>	10 - 15 $\mu$ s
<b>SIGNAL OUTPUT</b>	NPN Open Collector (24 VDC max., 50 mA) 150 $\mu$ s typical
<b>PHASE SHIFT</b>	Internal mode only by using the "+" and "-" switches
<b>EXT. TRIGGER</b>	a) 12-24 VDC thru a 3-wire NPN output sensor (requires external power supply)
<b>INPUT SIGNAL</b>	b) 12 VDC thru a 2-wire proximity sensor (leakage current 1 mA max., Load current 8 mA min.) c) Switch or Relay contact
<b>POWER REQUIREMENTS</b>	115 VAC $\pm$ 10% 60/50 Hz
<b>OPERATING TEMPERATURE</b>	32° – 104° F (0 – 40° C)
<b>DIMENSIONS</b>	9" L x 4.3" W x 8.5" H (Height includes handle)
<b>WEIGHT</b>	1.5 lbs. (0.7 Kg)
<b>ACCESSORIES AVAILABLE</b>	Carrying Case

## Flash Tube Replacement

When FPM reading is displayed but unit is not flashing, flash tube may need to be replaced.

1. Unplug line cord from power line. Turn power switch OFF. Wait a few minutes until stroboscope is cool before replacing flash tube.
2. Remove protective window by removing the 4 screws.
3. Use a rag and pull the tube out of its socket by rocking it slightly up and down. Do not use bare hands to remove tube, it may break and cause injury.
4. Insert new tube using the technique mentioned above. Make sure that the tube is placed properly in the socket otherwise it will touch the reflector. Tube should be set symmetrically within the neck of the reflector.
5. Replace protective window.

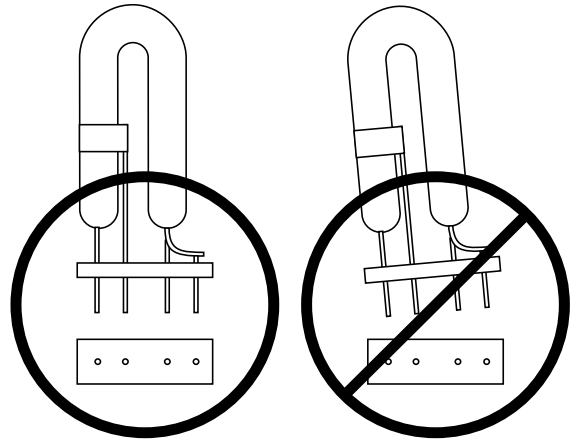

## Dimensions (mm)

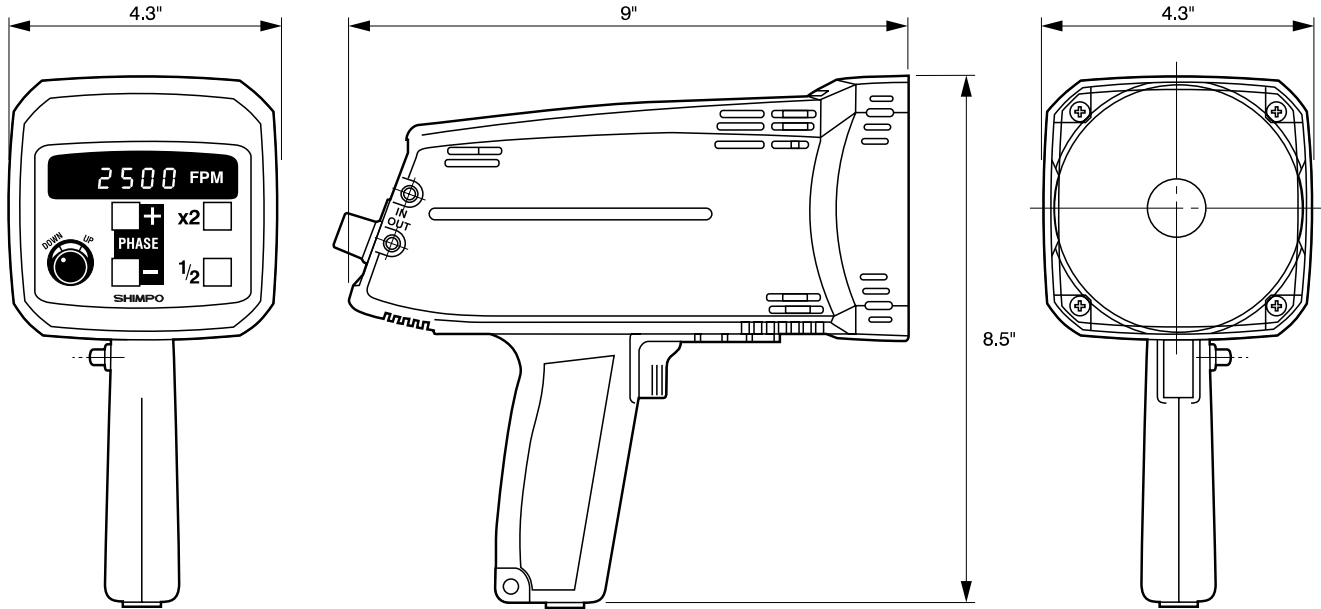

## SHIMPO ONE-YEAR WARRANTY

**LIMITED EXPRESS WARRANTY:** Shimpo Instruments warrants, to the original purchaser of new products only, that this product shall be free from defects in workmanship and materials under normal use and proper maintenance for one year from the date of original purchase. This warranty shall not be effective if the product has been subject to overload, misuse, negligence, or accident, or if the product has been repaired or altered outside of Shimpo Instruments's authorized control in any respect which in Shimpo Instruments's judgment, adversely affects its condition or operation.

**DISCLAIMER OF ALL OTHER WARRANTIES:** The foregoing warranty constitutes the SOLE AND EXCLUSIVE WARRANTY, and Shimpo Instruments hereby disclaims all other warranties, expressed, statutory or implied, applicable to the product, including, but not limited to all implied warranties of merchantability and fitness.

**LIMITATION OF REMEDY:** Under this warranty, Shimpo Instruments's SOLE OBLIGATION SHALL BE TO REPAIR OR REPLACE the defective product or part, at Shimpo Instruments's option. Shimpo Instruments reserves the right to satisfy warranty

obligation in full by reimbursing Buyer for all payments made to Shimpo Instruments, whereupon, title shall pass to Shimpo Instruments upon acceptance of return goods. To obtain warranty service, Purchaser must obtain Shimpo Instruments's authorization before returning the product, properly repackaged, freight pre-paid to Shimpo Instruments.

**INDEMNIFICATION & LIMITATION OF DAMAGES:** Buyer agrees to indemnify and hold Shimpo Instruments harmless from and against all claims and damages imposed upon or incurred arising, directly or indirectly, from Buyer's failure to perform or satisfy any of the terms described herein. In no event shall Shimpo Instruments be liable for injuries of any nature involving the product, including incidental or consequential damages to person or property, any economic loss or loss of use.

**MERGER CLAUSE:** Any statements made by the Seller's representative do not constitute warranties except to the extent that they also appear in writing. This writing constitutes the entire and final expression of the parties' agreement.