



$\frac{1}{4}$ -DIN SETPOINT PROGRAMMER

Site Manual

59216-1

PREFACE

This manual is intended for use in support of installation, commissioning and configuration of the $\frac{1}{4}$ -DIN Setpoint Programmer. For information on the day-to-day operation, refer to the associated Operator's manual (see below).

Associated Documents

Title	Part No.
$\frac{1}{4}$ -DIN Setpoint Programmer Operator's Manual	59215



The procedures described in this manual must be undertaken only by technically-competent and authorised servicing personnel.

Contents

1	INTRODUCTION	1-1
2	INSTALLATION	2-1
2.1	UNPACKING PROCEDURE	2-1
2.2	PANEL-MOUNTING THE SETPOINT PROGRAMMER	2-1
2.3	CONNECTIONS AND WIRING	2-4
2.3.1	Mains (Line) Input	2-5
2.3.2	24V (Nominal) AC/DC Supply	2-5
2.3.3	Thermocouple Input	2-7
2.3.4	RTD Inputs	2-7
2.3.5	Linear Inputs	2-7
2.3.6	Digital Inputs	2-7
2.3.7	Relay Outputs	2-8
2.3.8	SSR Drive Outputs.	2-9
2.3.9	DC Outputs.	2-9
2.3.10	Event Outputs	2-9
2.3.11	RS485 Serial Communications Link.	2-9
3	INTERNAL LINKS AND SWITCHES	3-1
3.1	REMOVING THE SETPOINT PROGRAMMER FROM ITS HOUSING	3-1
3.2	REMOVING/REPLACING THE OUTPUT 2/OUTPUT 3 OPTION PCBs	3-3
3.3	REMOVING/REPLACING THE RS485 COMMUNICATIONS OPTION PCB	3-3
3.4	INSTALLING/REMOVING THE DIGITAL INPUT OPTION PCB	3-4
3.5	INSTALLING/REMOVING THE EVENT OUTPUT OPTION PCB	3-5
3.6	REPLACING THE SETPOINT PROGRAMMER IN ITS HOUSING	3-5
3.7	SELECTION OF INPUT TYPE	3-6
3.8	SELECTION OF PRIMARY OUTPUT (OUTPUT 1) TYPE.	3-7
3.9	OUTPUT 2 TYPE/OUTPUT 3 TYPE	3-8
4	CONFIGURATION MODE	4-1
4.1	ENTRY INTO CONFIGURATION MODE.	4-1

4.2	HARDWARE DEFINITION CODE	4-1
4.3	CONFIGURATION MODE PARAMETERS	4-4
4.4	ALARM INHIBIT FACILITY	4-7
4.5	EXIT FROM CONFIGURATION MODE	4-7
5	SERIAL COMMUNICATIONS - ASCII PROTOCOL	5-1
5.1	RS485 CONNECTIONS	5-1
5.2	COMMUNICATIONS ENABLE/DISABLE	5-1
5.3	SELECTION OF COMMUNICATIONS ADDRESS	5-1
5.4	ASCII COMMUNICATIONS PROTOCOL	5-1
5.4.1	Type 1 Message	5-3
5.4.2	Type 2 Message	5-3
5.4.3	Type 3 Message	5-4
5.4.4	Type 4 Message	5-4
5.5	PROGRAMMER PARAMETERS (Start of Message character = R)	5-5
5.6	PROGRAMMER COMMANDS	5-8
5.7	PROGRAMMER STATUS 1	5-8
5.8	CURRENT SEGMENT EVENT STATUS	5-9
5.9	POWER FAIL RECOVERY	5-9
5.10	PROGRAM/SEGMENT DEFINITIONS	5-9
5.11	PROGRAM SCAN TABLE.	5-10
5.12	SEGMENT MODE	5-10
5.13	PROGRAMMER STATUS 2	5-11
5.14	USER TAG NAMES.	5-11
5.15	CONTROLLER PARAMETERS (Start of Message character = L)	5-12
5.16	CONTROLLER SCAN TABLE	5-16
5.17	ERROR RESPONSE	5-16
5.18	MASTER COMMUNICATIONS MODE.	5-16
6	MODBUS RTU SERIAL COMMUNICATIONS	6-1
6.1	COMMUNICATIONS WRITE ENABLE/DISABLE	6-1
6.2	PHYSICAL REQUIREMENTS	6-1
6.2.1	Character Transmission	6-1

6.2.2	Line Turn-round	6-1
6.3	MODBUS RTU PROTOCOL	6-1
6.3.1	Message Formats	6-2
6.3.2	Error and Exception Responses	6-6
6.3.3	Address Range	6-6
6.3.4	Bit Parameters	6-7
6.3.5	Word Parameters	6-7
6.4	PROGRAMMER COMMANDS	6-11
6.5	PROGRAMMER STATUS 1	6-11
6.6	SEGMENT MODE	6-12
6.7	PROGRAMMER STATUS 2	6-12
6.8	CURRENT SEGMENT EVENT STATUS	6-12
6.9	POWER FAIL RECOVERY	6-12

A PRODUCT SPECIFICATION

A-1

SECTION 1

INTRODUCTION

The Setpoint Programmer is equipped with a universal (thermocouple, RTD or linear) input and up to three outputs (relay, SSR or linear). It can be panel-mounted in an appropriate-sized cut-out using the “no-tools” fixing strap supplied. Several instruments can be installed in a side-by-side multiple installation in one single cut-out.

The Setpoint Programmer is front-panel configurable, enabling the user to tailor the instrument to suit the application.

The Setpoint Programmer is equipped with a 96 - 264V 50/60Hz power supply as standard; a 24V AC/DC option is available.

The Setpoint Programmer is constructed such that, once the instrument is correctly configured and installed, most changes to its use or application can be accommodated without removing it from its panel installation.

The options available on the Setpoint Programmer include:

- Remote control and selection of program via a Digital Input Option PCB

- Second control (COOL) output

- Valve motor drive (VMD) output

- Up to four Event relay outputs via an Event Output Option PCB

- Recorder output (setpoint or process variable)

- RS485 serial communications (ASCII or MODBUS protocol)

- Real Time Clock

For a full list of options, refer to Appendix A.

SECTION 2 INSTALLATION

2.1 UNPACKING PROCEDURE

1. Remove the Setpoint Programmer from its packing. The Setpoint Programmer is supplied with a panel gasket and push-fit fixing strap. Retain the packing for future use, should it be necessary to transport the Setpoint Programmer to a different site or to return it to the supplier for repair/testing.
2. Examine the delivered items for damage or deficiencies. If any is found, notify the carrier immediately.

2.2 PANEL-MOUNTING THE SETPOINT PROGRAMMER

The panel on which the Setpoint Programmer is to be mounted must be rigid and may be up to 6.0mm (0.25 inches) thick. The cut-out required for a single etpoint Programmer is as shown in Figure 2-1.

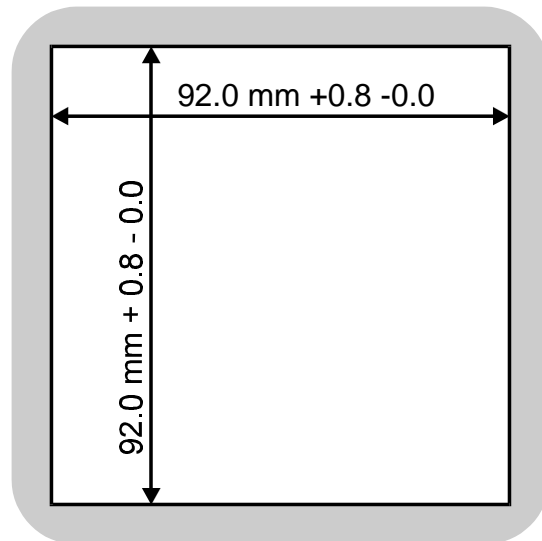

Figure 2-1 Cut-out Dimensions

Several controllers may be installed in a single cut-out, side-by-side. For n Setpoint Programmers mounted side-by-side, the width of the cut-out would be:

$$(96n - 4) \text{ millimetres or } (7.56n - 0.16) \text{ inches.}$$

The Setpoint Programmer is 100mm deep (measured from the rear face of the front panel). The front panel is 96mm high and 96mm wide. When panel-mounted, the front panel projects 10mm from the mounting panel. The main dimensions of the Setpoint Programmer are shown in Figure 2-2.

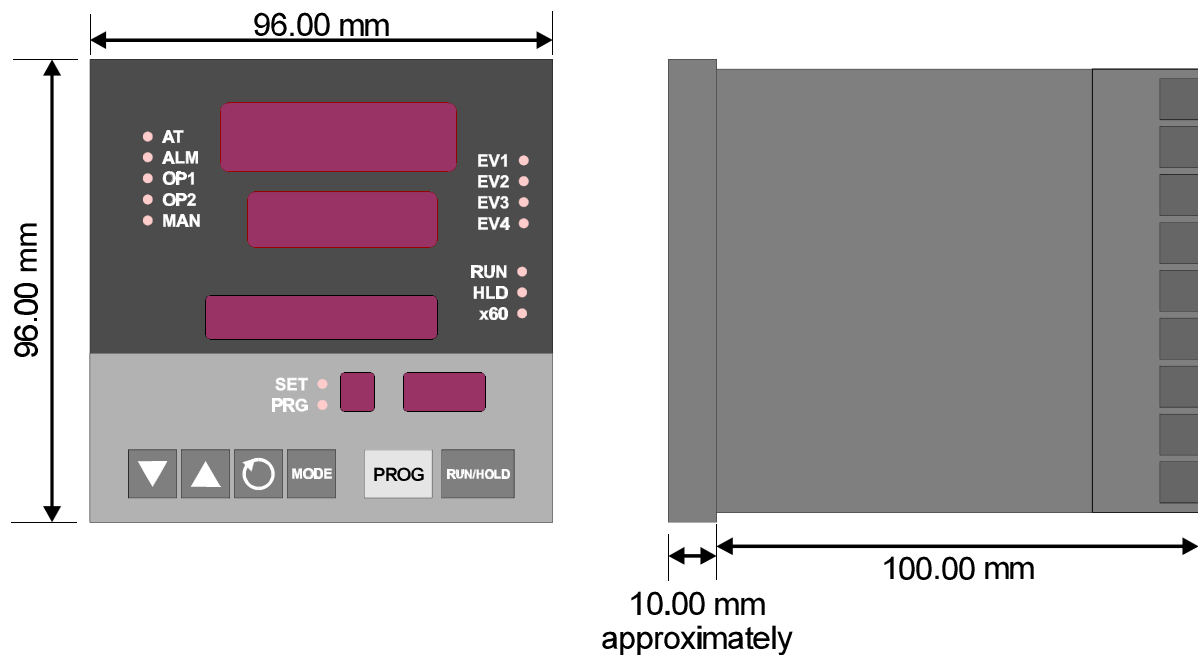

Figure 2-2 Principal Dimensions

To panel-mount the Setpoint Programmer:

1. Insert the rear of the Setpoint Programmer housing through the cut-out (from the front of the mounting panel) and hold the Setpoint Programmer lightly in position against the panel. Ensure that the panel gasket is not distorted and that the Setpoint Programmer is positioned squarely against the mounting panel. *Apply pressure to the front panel bezel only.*



CAUTION: Do not remove the panel gasket, as this may result in inadequate clamping of the instrument in the panel.

2. Slide the fixing strap in place (see Figure 2-3) and push it forward until it is firmly in contact with the rear face of the mounting panel (the tongues on the strap should have engaged in matching ratchet positions on the Setpoint Programmer housing and the fixing strap springs should be pushing firmly against the mounting panel rear face).

Once the Setpoint Programmer is installed in its mounting panel, it may be subsequently removed from its housing, if necessary, as described in Subsection 3.1.

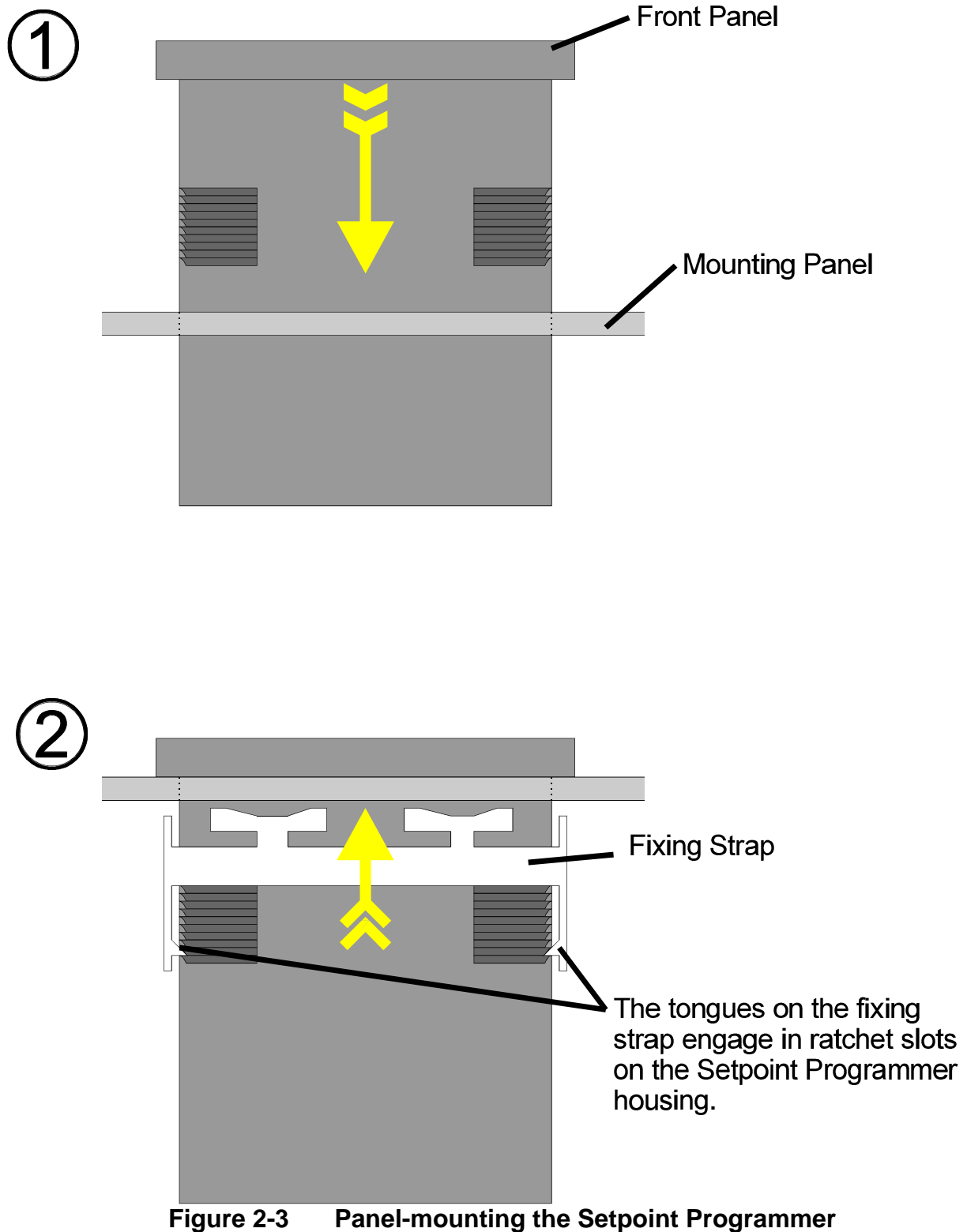

Figure 2-3 Panel-mounting the Setpoint Programmer

2.3 CONNECTIONS AND WIRING

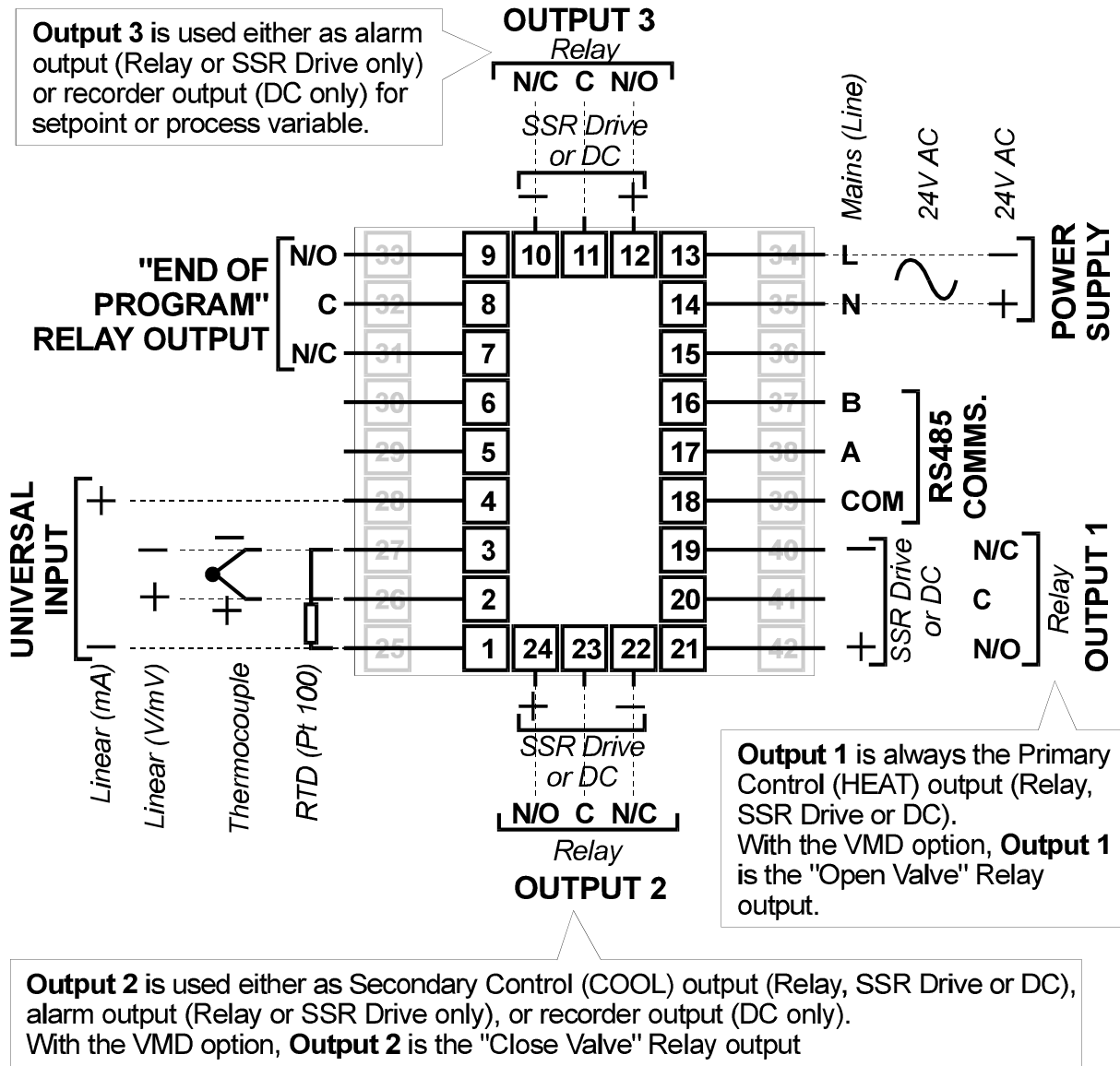

Figure 2-4 Rear Terminals

2.3.1 Mains (Line) Input

The Setpoint Programmer will operate on 96 - 264V AC 50/60Hz mains (line) supply. The power consumption is approximately 4 VA.



CAUTION: This equipment is designed for installation in an enclosure which provides adequate protection against electric shock. Local regulations regarding electrical installation should be rigidly observed. Consideration should be given to prevention of access to the power terminations by unauthorised personnel. Power should be connected via a two-pole isolating switch (preferably situated near the equipment) and a 1A fuse, as shown in Figure 2-5.

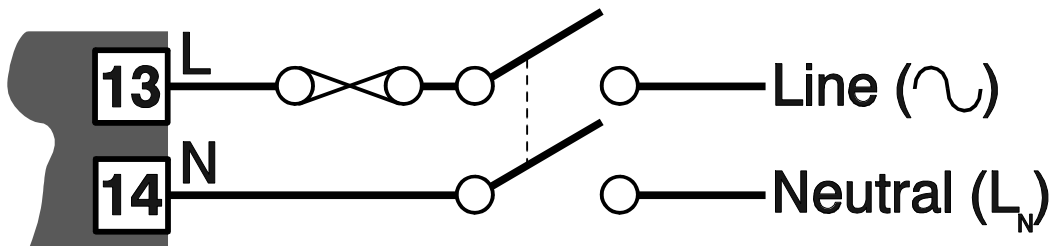

Figure 2-5 Mains (Line) Supply Connections

If the Setpoint Programmer has relay outputs in which the contacts are to carry mains (line) voltage, it is recommended that the relay contact mains (line) supply should be switched and fused in a similar manner but should be separate from the Setpoint Programmer mains (line) supply.

2.3.2 24V (Nominal) AC/DC Supply

The supply connections for the 24V AC/DC option of the Setpoint Programmer are as shown in Figure 2-6. Power should be connected via a two-pole isolating switch and a 315mA slow-blow (anti-surge Type T) fuse.

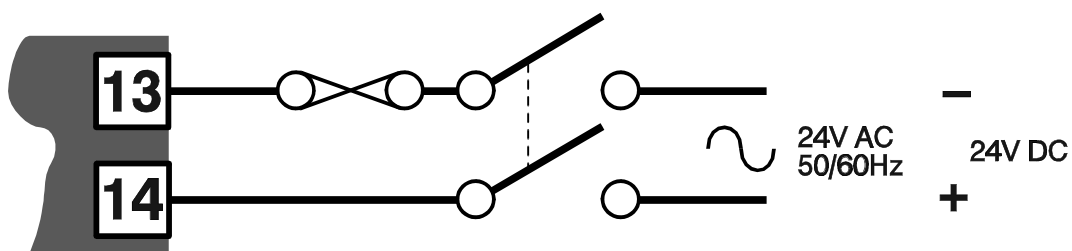

Figure 2-6 24V AC/DC Supply Connections

With the 24V AC/DC supply option fitted, these terminals will accept the following supply voltage ranges:

24V (nominal) AC 50/60Hz -	20 - 50V
24V (nominal) DC -	22 - 65V

Table 2-1 Thermocouple Cable Colour Codes

Thermocouple Type	Cable Material	British			
		(BS1843: 1952)	(BS4937: Part 30: 1993)	American (ASTM)	German (DIN)
T	Copper Constantan	+ White	+ Brown	+ Blue	+ Red
		- Blue	- White	- Red	- Brown
		* Blue	* Brown	* Blue	* Brown
J	Iron/Constantan	+ Yellow	+ Black	+ White	+ Red
		- Blue	- White	- Red	- Blue
		* Black	* Black	* Black	* Blue
K	Nickel Chromium Nickel Aluminium	+ Brown	+ Green	+ Yellow	+ Red
		- Blue	- White	- Red	- Green
		* Red	* Green	* Yellow	* Green
R S	13% Copper 10% Copper Nickel	+ White	+ Orange	+ Black	+ Red
		- Blue	- White	- Red	- White
		* Green	* Orange	* Green	* White
B	Platinum/Rhodium	+ Grey	+ Grey	+ Grey	+ Red
		- White	- White	- Red	- White
		* Grey	* Grey	* Grey	* White

* Colour of overall sheath.

2.3.3 Thermocouple Input

The correct type of thermocouple extension leadwire or compensating cable must be used for the entire distance between the Setpoint Programmer and the thermocouple, ensuring that the correct polarity is observed throughout. Joints in the cable should be avoided, if possible. The Setpoint Programmer's CJC facility must be enabled (normal conditions) for this input (see Subsection 4.3).

NOTE: Do not run thermocouple cables adjacent to power-carrying conductors. If the wiring is run in a conduit, use a separate conduit for the thermocouple wiring. If the thermocouple is grounded, this must be done at one point only. If the thermocouple extension lead is shielded, the shield must be grounded at one point only.

The colour codes used on thermocouple extension leads are shown in Table 2-1.

2.3.4 RTD Inputs

The compensating lead should be connected to Terminal 3. For two-wire RTD inputs, Terminals 2 and 3 should be linked. The extension leads should be of copper and the resistance of the wires connecting the resistance element should not exceed 5 ohms per lead (the leads should be of equal resistance).

2.3.5 Linear Inputs

For linear mA input ranges, connection is made to Terminals 1 and 4 in the polarity shown in Figure 2-4. For linear mV and V ranges, connection is made to Terminals 2 and 3 in the polarity shown in Figure 2-4. For details of the linear input ranges available, refer to Appendix A.

2.3.6 Digital Inputs

These inputs will accept TTL, Open Collector or voltage-free (switch) connections. A Digital Input Option PCB must be fitted and the External Option parameter (in Configuration Mode - see Subsection 4.2 of this manual) must be set to **inP** or **both** for these terminals to be operable. The degree of external selection/control is defined by the External Selection parameter in Program Define Mode (see Operator's Manual, Section 8). It is assumed that all external selection/run control functions are enabled for the purposes of this description.

Terminals 31 (R2) to 33 (R0) provide a binary-coded input which is used to select the program:

Digital Inputs = TTL Level			Digital Inputs = Contavts (switches)				
Digital Inputs			Program Selected	Digital Inputs			Program Selected
R0	R1	R2		R0	R1	R2	
0	0	0	Program 1	Closed	Open	Open	Program 1
1	0	0	Program 2	Open	Closed	Open	Program 2
0	1	0	Program 3	Closed	Closed	Open	Program 3
1	1	0	Program 4	Open	Open	Closed	Program 4
0	0	1	Program 5	Closed	Open	Closed	Program 5
1	0	1	Program 6	Open	Closed	Closed	Program 6
0	1	1	Program 7	Closed	Closed	Closed	Program 7
1	1	1	Program 8	Open	Open	Open	Program 8

For the Program Control inputs, the following convention has been adopted: for TTL inputs OFF = logic 0, ON = logic 1; for contact (switch) inputs, OFF = open, ON = closed.

Terminal 30 is the Program Abort control. It is edge-sensitive; an OFF-ON transition at any time will cause an immediate Program Abort.

Terminal 29 provides the remote Run Program/Hold Program control and has an identical effect to that of the Run/Hold key on the front panel. An OFF-ON transition will cause the currently-selected program to be run (or to be resumed if it is currently held); An ON-OFF transition will cause the currently-running program to be held. *Powering-up the Setpoint Programmer with this terminal ON will not cause a program to run.*

Terminal 28 provides the "x60" program timebase selection. This terminal is level-sensitive: ON (contacts closed) = minutes/seconds, OFF (contacts open) = hours/minutes). *When the Setpoint Controller is powered-up, the initially-selected timebase will be according to the level on this terminal at power-up.*

NOTE: All remote selection/control functions except the Abort function have precedence over the corresponding front panel controls. The "x60" function will also take precedence over any "Pre-set x60" parameter setting (see Operator Manual, Section 8).

2.3.7 Relay Outputs

Outputs 1, 2 and 3: contacts rated at 2A resistive at 120/240V AC.

End of Program/Event outputs: contacts rated at 5A resistive at 120/240V AC.

NOTE: With VMD control, either Output 1 or Output 2 is switched on (to open or close the valve) However, under fault conditions, both Output 1 and Output 2 relays could be switched on simultaneously. For safety purposes, an interlock can be included which connects the supply to the motor via the "normally closed" contacts on the Output 1 and Output 2 relays (see Figure 2-7).

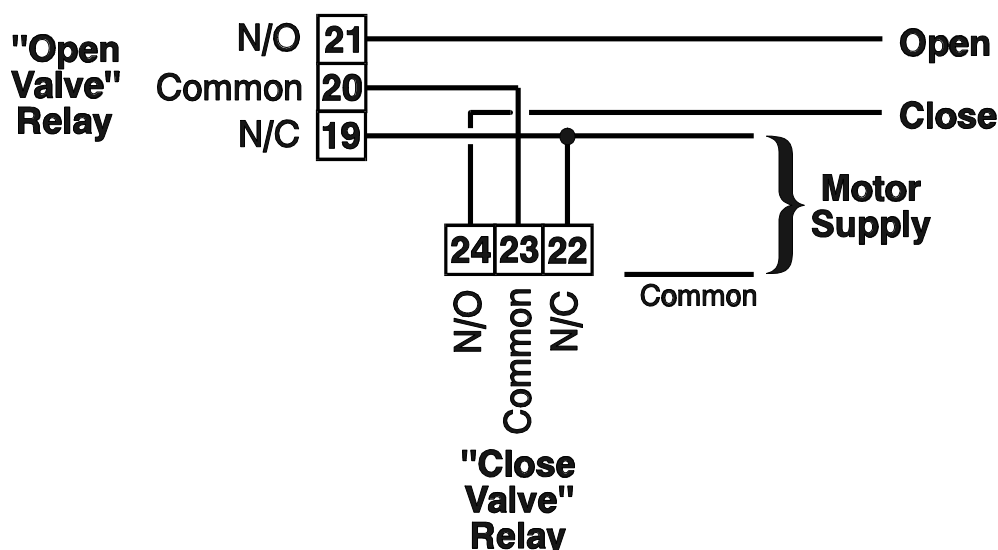

Figure 2-7 Valve Motor Drive Outputs with Interlock

2.3.8 SSR Drive Outputs

These outputs produce a time-proportioned non-isolated DC signal (0 - 4.3V nominal, output impedance 250 ohms).

2.3.9 DC Outputs

See Appendix A.

2.3.10 Event Outputs

These outputs are only available if the Event Output PCB is fitted and if the External Option parameter in Configuration Mode (see Subsection 4.2 of this manual) is set to either **out** or **both**. They are single pole single throw Normally Open relay contacts. For the current segment of the currently-running/held program, these outputs are in the states defined by the Event parameter (see Operator's Manual, Section 8) for that segment. 0 = open, 1 = closed.

2.3.11 RS485 Serial Communications Link

The "A" terminal (Terminal 17) on the Setpoint Programmer should be connected to the "A" terminal on the master device; the "B" terminal (Terminal 16) on the Setpoint Programmer should be connected to the "B" terminal on the master device. Where several Setpoint Programmers are connected to one master port, the master port transceiver in the active state should be capable of driving a load of 12k Ω per Setpoint Programmer; the master port transceiver in the passive state must have pull-up/pull-down resistors of sufficiently low impedance to ensure that it remains in the quiescent state whilst supplying up to $\pm 100\mu\text{A}$ each to the Setpoint Programmer transceivers in the high impedance state.

SECTION 3

INTERNAL LINKS AND SWITCHES

3.1 REMOVING THE SETPOINT PROGRAMMER FROM ITS HOUSING



CAUTION: Before removing the Setpoint Programmer from its housing, ensure that all power has been removed from the rear terminals.

To withdraw the Setpoint Programmer from its housing, simply grip the side edges of the front panel (there is a finger grip on each edge) and pull the panel forwards. This will release the Setpoint Programmer from its rear connectors in the housing and will give access to the PCBs. Take note of the orientation of the Setpoint Programmer for subsequent replacement into the housing. The positions of the PCBs are shown in Figure 3-1.

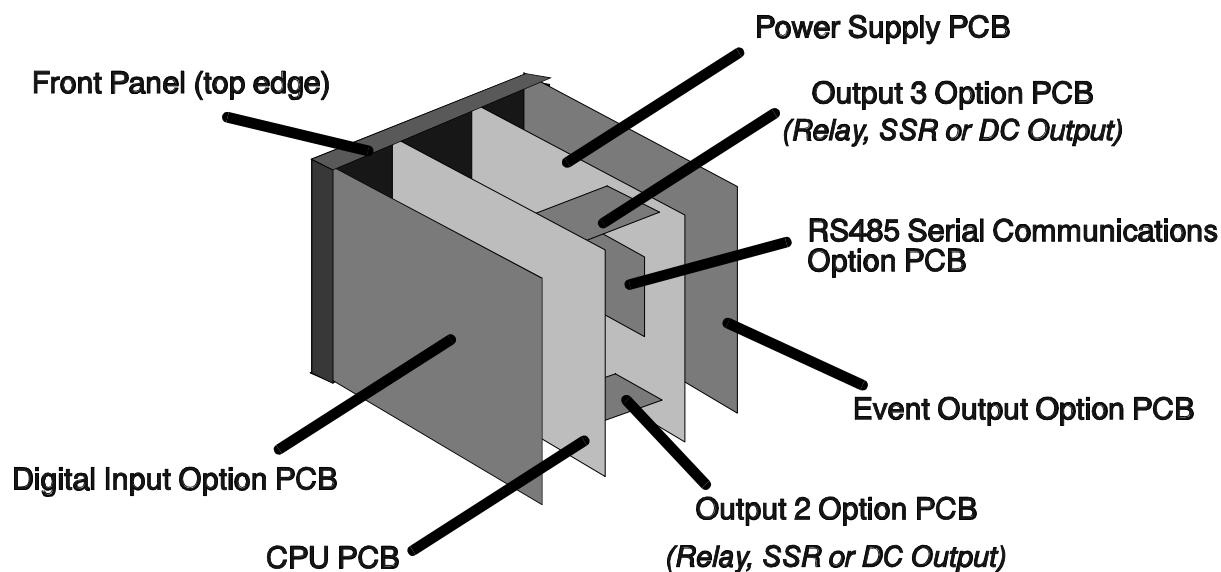

Figure 3-1 PCB Positions

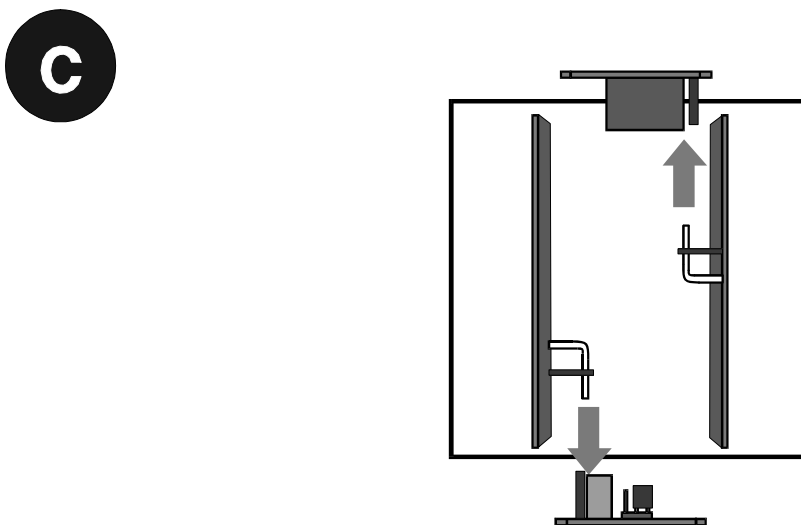
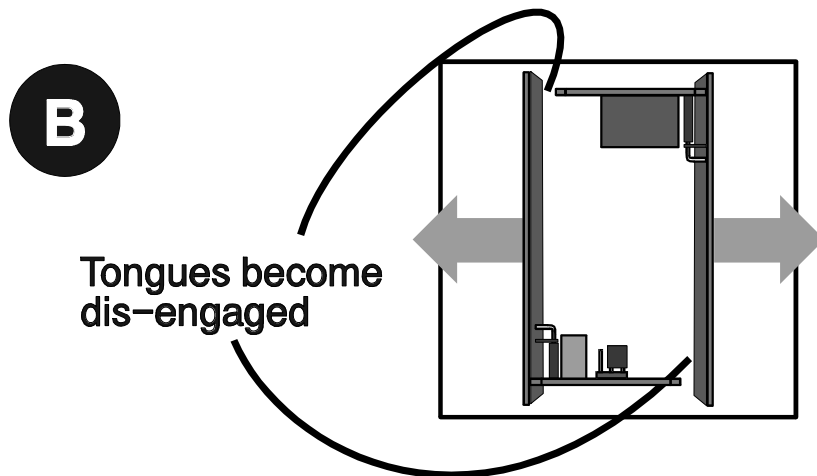
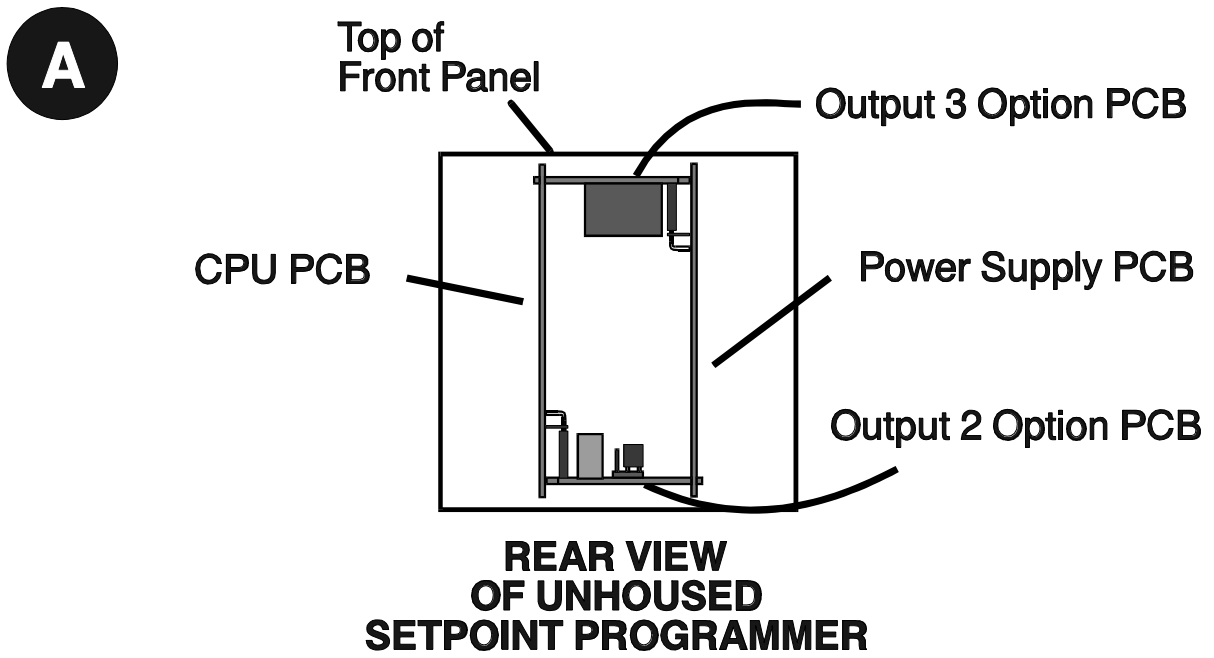

Figure 3-2 Removing the Output 2/Output 3 Option PCBs

3.2 REMOVING/REPLACING THE OUTPUT 2/OUTPUT 3 OPTION PCBs

With the Setpoint Programmer removed from its housing:

1. Gently push the rear ends of the CPU PCB and Power Supply PCB apart slightly, until the two tongues on each of the Output 2/Output 3 Option PCBs become dis-engaged - see Figure 3-2B; The Output 2 Option PCB tongues engage in holes in the Power Supply PCB and the Output 3 Option PCB tongues engage in holes on the CPU PCB.
2. Carefully pull the required Option PCB (Output 2 or Output 3) from its connector (Output 2 Option PCB is connected to the CPU PCB and Output 3 Option PCB is connected to the Power Supply PCB) - see Figure 3-2C. Note the orientation of the PCB in preparation for its replacement.

Adjustments may now be made to the link jumpers on the CPU PCB, the Output 2/Output 3 Option PCBs (if DC output) and (if fitted) the DC Output 1 PCB. The replacement procedure is a simple reversal of the removal procedure.

3.3 REMOVING/REPLACING THE RS485 COMMUNICATIONS OPTION PCB

The RS485 Communications Option PCB is mounted on the inner surface of the Power Supply PCB and can be removed when the Setpoint Programmer is removed from its housing (see Subsection 3.1) Figure 3-3 illustrates the removal/replacement procedure. *It is not necessary to remove the Output 2/Output 3 Option PCBs to perform this procedure.*

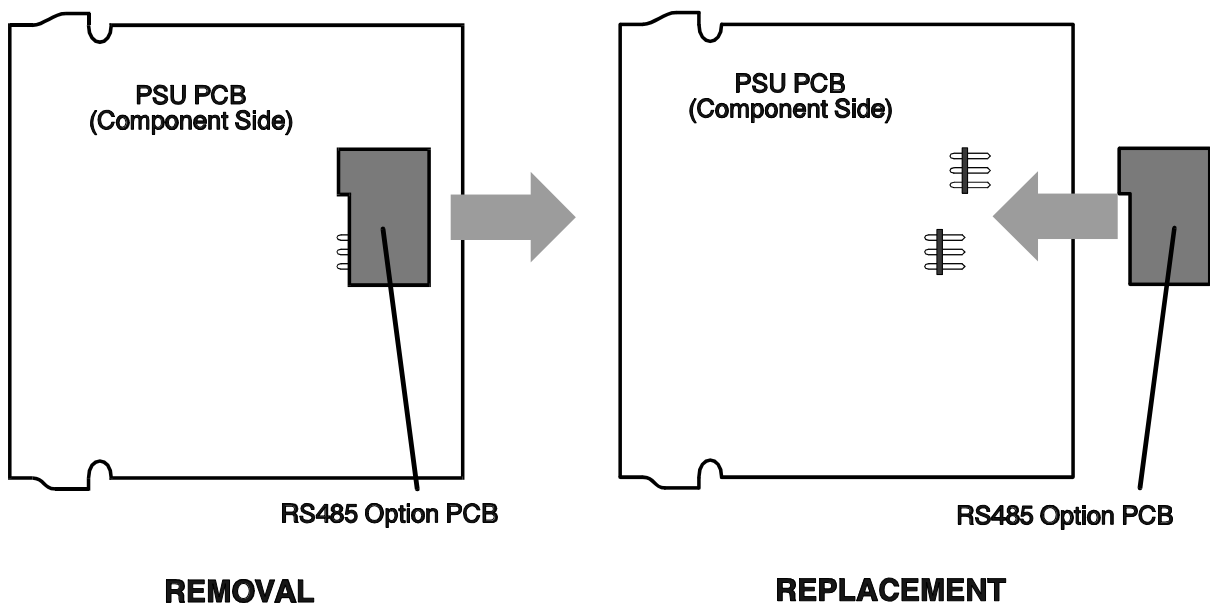
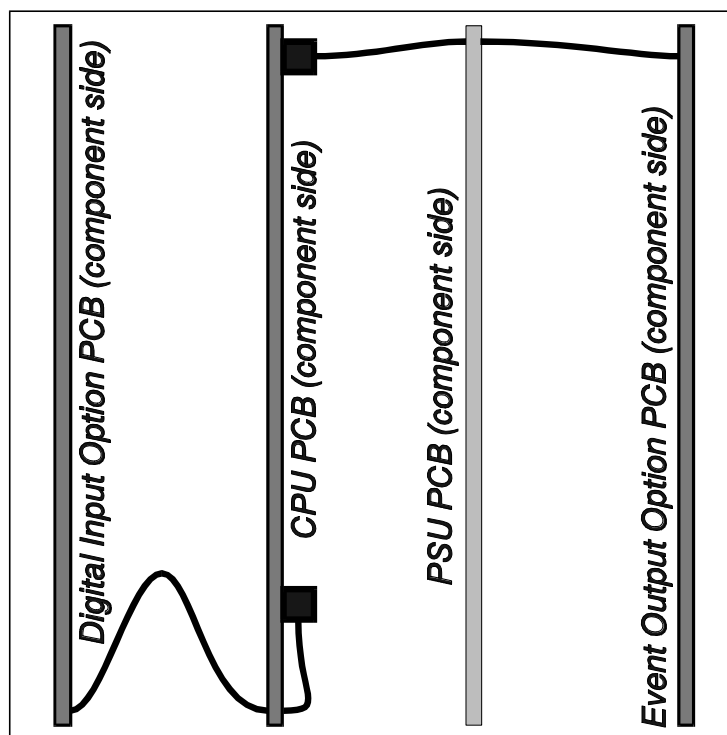

Figure 3-3 Removing/Replacing the RS485 Communications Option PCB

3.4 INSTALLING/REMOVING THE DIGITAL INPUT OPTION PCB

The location of the Digital Input Option PCB is shown in Figure 3-4. It is connected to the CPU PCB via a flexi-strip connector, as shown.



REAR VIEW OF UNHOUSED INSTRUMENT

Figure 3-4 Location of Digital Input Option PCB and Event Output Option PCB

To install the Digital Input Option PCB:

1. Hold the PCB approximately in position and carefully insert the free end of the flexi-strip cable into the socket near the bottom edge of the CPU PCB (ensuring that none of the pins on the end of the flexi-strip become bent and that the flexi-strip is not twisted).
2. Fully insert the Digital Input Option PCB into its connector at the rear of the front panel (when the PCB is fully inserted, it will become engaged in the slots above and below its connector).

To remove the Digital Input Option PCB:

1. Dis-engage the PCB from its slots (above and below the connector at the rear of the front panel) and withdraw the PCB clear of the connector.
2. Disconnect the flexi-strip from the connector near the bottom edge of the CPU PCB.
3. Remove the Digital Input Option PCB completely from the instrument.

3.5 INSTALLING/REMOVING THE EVENT OUTPUT OPTION PCB

The location of the Event Output Option PCB is shown in Figure 3-4. It is connected to the CPU PCB via a flexi-strip connector, as shown.

To install the Event Output Option PCB:

1. Hold the PCB approximately in position and carefully insert the free end of the flexi-strip cable into the socket near the top edge of the CPU PCB (ensuring that none of the pins on the end of the flexi-strip become bent and that the flexi-strip is not twisted).
2. Fully insert the Event Output Option PCB into its connector at the rear of the front panel (when the PCB is fully inserted, it will become engaged in the slots above and below its connector).

To remove the Event Output Option PCB:

1. Dis-engage the PCB from its slots (above and below the connector at the rear of the front panel) and withdraw the PCB clear of the connector.
2. Disconnect the flexi-strip from the connector near the top edge of the CPU PCB.
3. Remove the Event Output Option PCB completely from the instrument.

3.6 REPLACING THE SETPOINT PROGRAMMER IN ITS HOUSING

To replace the Setpoint Programmer, simply align the CPU PCB and Power Supply PCB with their guides and connectors in the housing and slowly but firmly push the Setpoint Programmer into position.

CAUTION: Ensure that the instrument is correctly orientated. A stop will operate if an attempt is made to insert the instrument in the wrong orientation (e.g. upside-down). *This stop must not be over-ridden.*

3.7 SELECTION OF INPUT TYPE

The selection of input type is accomplished on link jumpers LJ1/LJ2/LJ3 on the CPU PCB (see Figure 3-5 and Table 3-1).

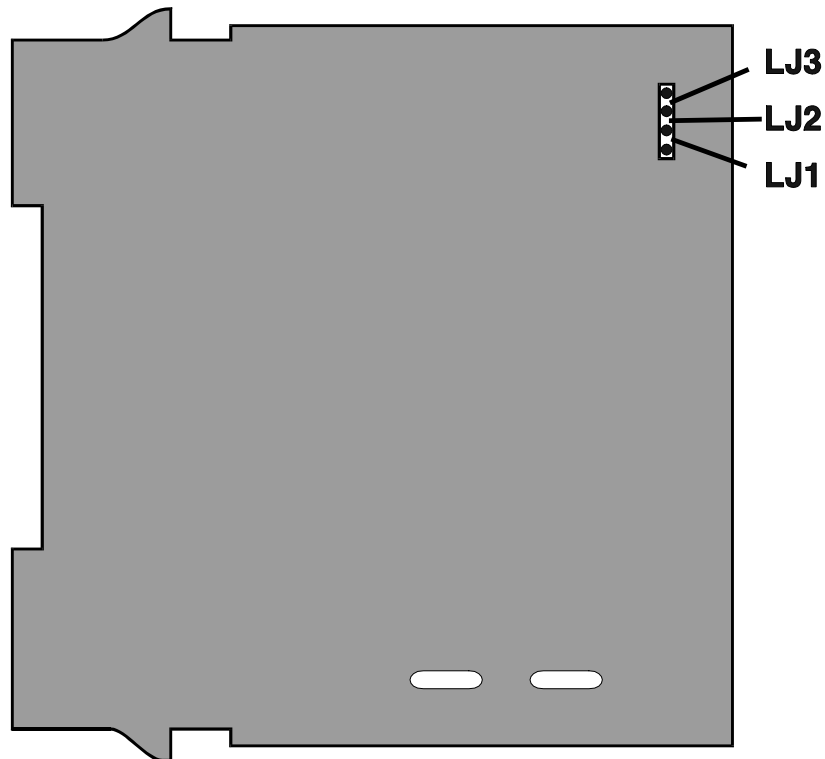

Figure 3-5 CPU PCB (Relay/SSR Drive Output 1)

Table 3-1 Input Type Selection

Input Type	Link Jumper Fitted
RTD or DC (mV)	None (parked)
Thermocouple	LJ3
DC (mA)	LJ2
DC (V)	LJ1

3.8 SELECTION OF PRIMARY OUTPUT (OUTPUT 1) TYPE

The required type of Output 1 is selected by Link Jumpers LJ4/LJ5/LJ6/LJ7/LJ8/LJ9 on the PSU PCB (see Figure 3-6 and Table 3-2).

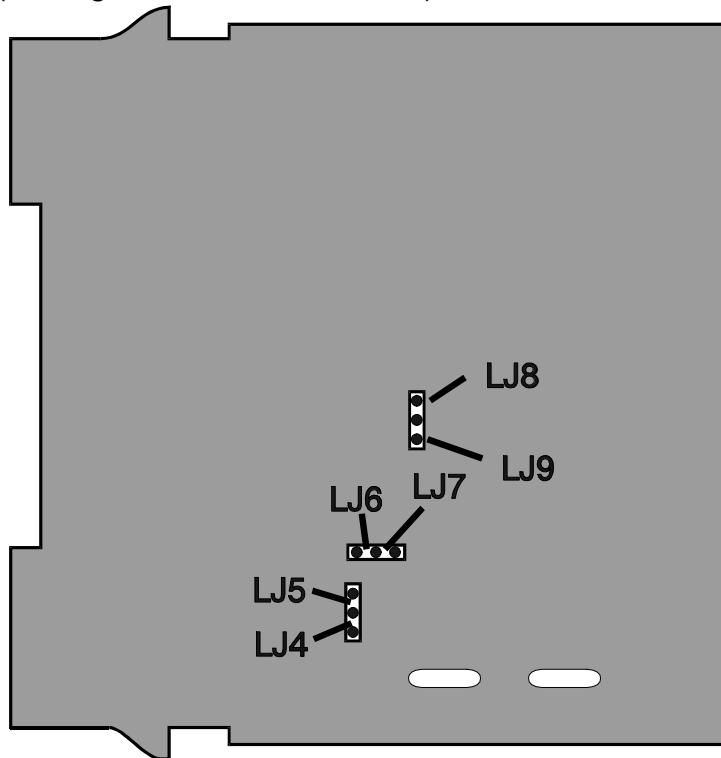

Figure 3-6 PSU PCB Link Jumpers

Table 3-2 Output 1 Type Selection

Output Type	Link Jumpers Fitted
Relay	LJ5 & LJ6
SSR Drive	LJ4 & LJ7
DC (0 - 10V)	LJ8
DC (0 - 20mA)	LJ9
DC (0 - 5V)	LJ8
DC (4 - 20mA)	LLJ9

3.9 OUTPUT 2 TYPE/OUTPUT 3 TYPE

The type of output for Output 2 and Output 3 is determined by the Option PCB fitted in the appropriate position (see Figure 3-1) and, in the case of the DC Output Option PCB being fitted, the setting of Link Jumpers LJ8 and LJ9 on that Option PCB (see Figure 3-7 and Table 3-3). There are three types of option PCB which may be used for Output 2 and Output 3:

1. Relay Output Option PCB (no link jumpers)
2. SSR Output Option PCB (no link jumpers)
3. DC Output Option PCB (link jumpers as shown in Figure 3-7)

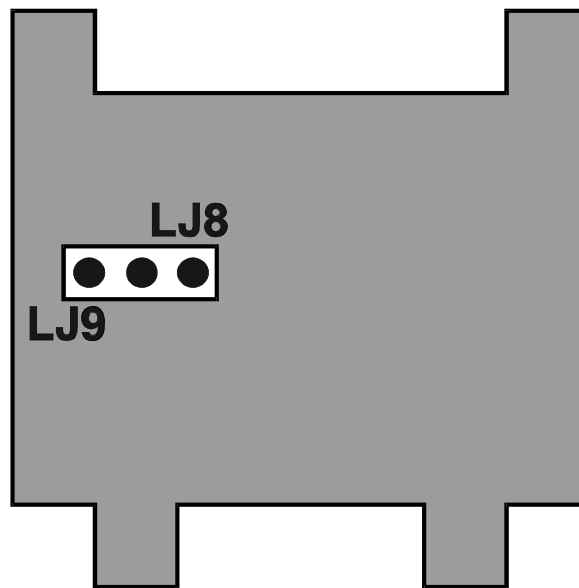

Figure 3-7 DC Output Option PCB (Output 2/Output 3)

Table 3-3 Output 2/Output 3 DC Output Type Selection

Output Type	Link Jumpers Fitted
DC (0 - 10V)	LJ8
DC (0 - 20mA)	LJ9
DC (0 - 5V)	LJ8
DC (4 - 20mA)	LJ9

SECTION 4 CONFIGURATION MODE

4.1 ENTRY INTO CONFIGURATION MODE

- ① Power-down the instrument.
- ② Power-up the instrument. All LEDs and indicators will come ON temporarily (automatic test routine) then the normal Base Mode display will appear.
- ③ Within 30 seconds of power-up, hold down the Up key and Scroll key for approximately five seconds. *This must be the first key action after power-up.*



The Setpoint Programmer is then in Configuration Mode:

-
- ① Select desired parameter with Scroll key
 - ② Adjust parameter to desired value/setting using the Up & Down keys. Parameter value display will flash.
 - ③ Confirm new value/setting by pressing the **MODE** key. The parameter value display will stop flashing.



NOTE: Changes to Configuration parameters (e.g. input range, output use and type) will cause the Program Define Mode and Controller Define Mode parameters to be set to their default values. *Adjust all Configuration Mode parameters to their desired values before adjusting Program Define and Controller Define Mode parameters.*

4.2 HARDWARE DEFINITION CODE

This specifies the hardware fitted (input type, output types etc.); this must be compatible with the hardware actually fitted. It can be accessed by pressing the Down and Scroll keys together. The Message Display will then show:

HwDefIne

and lower main display will be of the form:

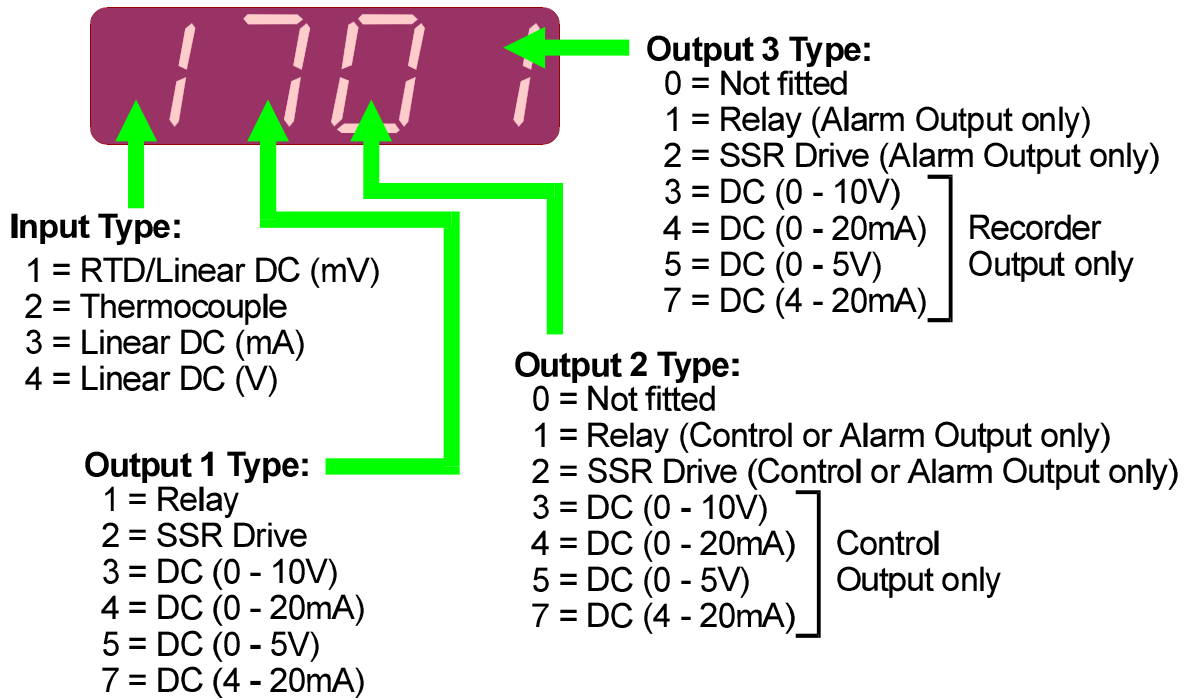

The displayed code may be incremented/decremented using the Up/Down keys as required. The maximum setting available for this code is 4777. For example, the code for a thermocouple input, DC 4 - 20mA primary output (Output 1) and relay Output 3 would be 2701. When the code is first altered, the code display will flash, until the desired value is displayed and confirmed by pressing the **MODE** key.

NOTE: It is essential that this code is changed promptly whenever there is a change to the Setpoint Programmer's hardware configuration (change of input/output type, alarm/recorder output added/removed etc.). The Setpoint Programmer software depends upon this code to operate correctly.

Hardware Definitions may be viewed as Read Only displays in Base Mode by pressing the Scroll and Down keys simultaneously.

Whilst the Hardware Definition Code is displayed, pressing the Scroll key will cause the Message Display to change to:



and the lower main display to change to one of:

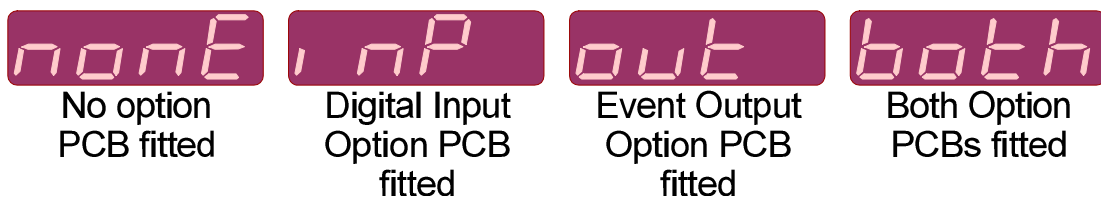

The desired setting can be achieved using the Up/Down keys.

Press the Scroll key to change the Message Display to:

Comms

and the lower main display to one of:

none

RS485
Communications
Option PCB
not fitted

SLA

RS485
Communications
Option PCB fitted -
Programmer acting
as slave device

MAST

RS485
Communications
Option PCB fitted -
Programmer acting
as master device

The desired setting can be achieved using the Up/Down keys. If the External Option parameter has not been set to **inP** or **both**, pressing the Scroll key will return to the initial External Option parameter display. If the External Option parameter has been set to either **inP** or **both**, pressing the Scroll key will change the Message Display to:

Inputs

and the lower main display to one of:

tTL

Digital Inputs
= TTL Level

cont

Digital Inputs
= Contacts (switches)

Digital Inputs = TTL Level				Digital Inputs = Contavts (switches)			
Digital Inputs			Program Selected	Digital Inputs			Program Selected
R0	R1	R2		R0	R1	R2	
0	0	0	Program 1	Closed	Open	Open	Program 1
1	0	0	Program 2	Open	Closed	Open	Program 2
0	1	0	Program 3	Closed	Closed	Open	Program 3
1	1	0	Program 4	Open	Open	Closed	Program 4
0	0	1	Program 5	Closed	Open	Closed	Program 5
1	0	1	Program 6	Open	Closed	Closed	Program 6
0	1	1	Program 7	Closed	Closed	Closed	Program 7
1	1	1	Program 8	Open	Open	Open	Program 8

For the Program Control inputs, the following convention has been adopted: for TTL inputs OFF = logic 0, ON = logic 1; for contact (switch) inputs, OFF = open, ON = closed.

The desired setting can be achieved using the Up/Down keys. Pressing the Scroll key will then return to the initial External Option parameter display. To exit from the Hardware Definition Code facility, press the Down and Scroll keys simultaneously (which will cause a return to the normal Configuration Mode). Alternatively, either of the methods of exit from Configuration Mode (see Subsection 4.5) may be used here.

4.3 CONFIGURATION MODE PARAMETERS

The Configuration Mode parameters are presented for view/edit in the following sequence:

Parameter	Message Display	Function	Available Settings/Values (Lower Main Display)
Primary Input Range ¹	Input	Displayed code defines input type & range (see Appendix A)	See Appendix A.
Control Action	Control	Specifies control action of Output 1 ²	Stdd Standard, direct-acting Stdr Standard, reverse-acting* rTdd VMD, direct-acting ‡ rTdr VMD, reverse-acting ‡
Alarm 1 Type	Alarm 1	Specifies Alarm 1 operation	P_h1 Process High* P_Lo Process Low dE Deviation bAnd Band nonE None
Alarm 2 Type	Alarm 2	Specifies Alarm 2 operation	P_h1 Process High* P_Lo Process Low dE Deviation bAnd Band nonE None
Alarm Inhibit (see Subsection 4.4)	Inhibit	Specifies which alarms are inhibited	nonE No inhibit* ALA1 Alarm 1 ALA2 Alarm 2 both Both alarms

* Default value/setting

‡ Not available if Output 1 and Output 2 are not relay outputs (see Subsection 4.2).

Parameter	Message Display	Function	Available Settings/Values (Lower Main Display)
Output 2 Usage NOTE: This parameter is not available if Control Action is set to Mdd or Mdr - Output 2 is automatically used as a control output.	Out2 Use	Specifies use of Output 2 ³	out2 Control Output ² A2_d Alarm 2 (direct) A2_r Alarm 2 (reverse) Or_d Alarm 1 OR 2 (direct) Or_r Alarm 1 OR 2 (reverse) Ad_d Alarm 1 AND 2 (direct) Ad_r Alarm 1 AND 2 (reverse) LP_d Loop Alarm (direct) LP_r Loop Alarm (reverse)
Output 3 Usage	Out3 Use	Specifies use of Output 3 ⁴	A1_d Alarm 1 (direct) A1_r Alarm 1 (reverse) Or_d Alarm 1 OR 2 (direct) Or_r Alarm 1 OR 2 (reverse) Ad_d Alarm 1 AND 2 (direct) Ad_r Alarm 1 AND 2 (reverse) LP_d Loop Alarm (direct) LP_r Loop Alarm (reverse) rEcS Recorder Output (SP) rEcP Recorder Output (PV)
Segment Mode	Seg Mode	Defines parameter used to specify duration of each segment (along with Final SP value)	t1 Time* rA Ramp Rate †
End of Program Relay operation	EOPRelay	Selects when End of Program relay is energised	End When program ends* run While program runs
Event State	Ev State	Selects whether Event Output states are held or reset at End of Program	HOLD Held OFF Reset*

* Default value/setting

† When x60 = OFF, Time = hours/minutes and Ramp Rate = LSD/hour
 When x60 = ON, Time = Minutes/seconds and Ramp Rate = LSD/minute

Parameter	Message Display	Function	Available Settings/Values (Lower Main Display)
Baud Rate ⁵	BaudRate	Selects Baud rate for RS485 Communications	Numeric value: 1200, 2400, 4800* or 9600
Communications Protocol ⁵	Protocol	Selects protocol for RS485 Communications	ASCII ASCII* RTU MODBUS RTU, no parity RTU MODBUS RTU, odd parity RTUE MODBUS RTU, even parity
Communications Address ^{5,6}	Address	Selects RS485 Communications address	ASCII protocol: 1* - 99 MODBUS RTU protocol: 1 - 255
CJC Enable/Disable ⁷	CJC	Enables/disables Cold Junction Compensation	EnAb Enabled* dISA Disabled
Number of Lock Codes	Locks	Selects one or two lock codes to be used	1* (common code) or 2 (separate codes for Controller Define Mode and Program Define Mode)
Lock Code ⁸	LockCode If 1 Lock Code, or: Lock P followed by: Lock C if 2 Lock Codes	Displays current lock code value(s)	Read Only - No adjustment in Configuration Mode - see Operator's manual.

* Default value/setting

NOTES ON CONFIGURATION PARAMETERS

1. The primary input range default setting is dependent upon the hardware fitted, as indicated in the Hardware definition Code (see Subsection 4.2):

Input Hardware Fitted	Default Setting
Thermocouple	1419 (Type "J", 0 - 760°C)
RTD/Linear (mV)	7220 (RTD Pt100 0 - 800°C)
Linear (mA)	3414 (4 - 20mA)
Linear (V)	4446 (0 - 10V)

2. If Output 2 is selected to be the secondary (COOL) control output, its action is always the complement of the action of Output 1.

3. The default setting for Output 2 Usage is Alarm 2 hardware output, direct-acting (if a relay/SSR drive output) or secondary (COOL) control output (if DC output).

4. The default setting for Output 3 Usage is Alarm 1 hardware output, direct-acting (if a relay/SSR drive output) or Process Variable Recorder Output (if a DC output).

5. Not available if the Hardware Definition **Comms** parameter is set to **nonE**.

6. Not available if the Hardware Definition **Comms** parameter is set to **MAS** (see Subsection 4.2).

7. Not available if input type is not thermocouple (see Subsection 4.2). If the CJC is disabled, the initial display in Operator Mode will show horizontal bars flashing in the lower main display.

8. Message Display will show Lock Code for 1 lock code or Lock P (Program Define Mode) followed by Lock C (Controller Define Mode) for 2 lock codes.

4.4 ALARM INHIBIT FACILITY

On power-up, an "alarm" condition may occur, based on the alarm value, the process variable value and, if appropriate to the alarm type, the setpoint value. This would normally activate an alarm; however, if the pertinent alarm is inhibited, the alarm indication is suppressed and the alarm will remain inactive. This will prevail until the "alarm" condition returns to the "inactive" state, whereafter the alarm will operate normally.

4.5 EXIT FROM CONFIGURATION MODE

To leave Configuration Mode, depress the Up and Scroll keys simultaneously.

NOTE: An automatic exit to Base Mode will be made if, in Configuration Mode, there is no front panel key activity for five minutes.

The exit is made via the power-up self-test routines which include a lamp test.

SECTION 5

SERIAL COMMUNICATIONS - ASCII PROTOCOL

The Setpoint Programmer may be equipped with a three-wire RS485-compatible serial communications facility, by which means communication may occur between the Setpoint Programmer and a master device (e.g. a computer or terminal) or up to 99 slave devices.

5.1 RS485 CONNECTIONS

The connections for the serial communications option are shown in Figure 2-4 and described in Subsection 2.3.11. Communication is at a user-selectable rate from the range 1200, 2400, 4800 and 9600 Baud and the cable used should be suitable for data transfer at the selected rate over the required distance. Transmitters/receivers conform to the recommendations in the EIA Standard RS485.

5.2 COMMUNICATIONS ENABLE/DISABLE

When Communications are enabled (in Controller Define Mode - see Operators' Manual), the Setpoint Programmer parameters may be adjusted by the master device via the serial communications link. If communications are disabled, the Setpoint Programmer will not adjust or change any parameters in response to commands received from the master device and will send a negative acknowledgement in response to such commands. Whether communications are enabled or disabled, the Setpoint Programmer will return the requested information in response to a Type 2 Interrogation message (see Subsection 5.4.2) from the master device.

5.3 SELECTION OF COMMUNICATIONS ADDRESS

The address for each Setpoint Programmer is defined in Configuration Mode (see Subsection 4.3). Up to 32 Setpoint Programmers, each with a unique address, may be connected to the master device.

5.4 ASCII COMMUNICATIONS PROTOCOL

The ASCII protocol assumes half duplex communications. All communication is initiated by the master device. The master sends a command or query to the addressed slave and the slave replies with an acknowledgement of the command or the reply to the query. All messages, in either direction, comprise:

- (a) A Start of Message character
 - R (Programmer Parameters) or L (Controller Parameters)
- (b) One or two address characters (uniquely defining the slave)
- (c) A parameter/data character string {DATA}

(d) An End of Message character

Messages from the master device may be one of five types:

Type 1: {S} {N} ? ? *
 Type 2: {S} {N} {P} {C} * or R {N} {P} {C} *
 Type 3: {S} {N} {P} # {DATA} * or R {N} {P} # {DATA} *
 Type 4: {S} {N} {P} I * or R {N} {P} I *
 Type 5: {S} {N} \ P S S ? *

where all characters are in ASCII code and:

{S} is the Start of Message character L (Hex 4C) or R (Hex 52). L is used for Controller parameters; R is used for Programmer parameters.

{N} is the slave Setpoint Programmer address (in the range 1 - 99); addresses 1 - 9 may be represented by a single digit (e.g. 7) or in two-digit form, the first digit being zero (e.g. 07).

{P} is a character which identifies the parameter to be interrogated/modified - see Table 5-2 (Programmer parameters) and Table 5-4 (Controller parameters).

{C} is the command (see Subsection 5.4.2)

indicates that {DATA} is to follow (Hex 23)

{DATA} is a string of numerical data in ASCII code (see Table 5-1)

P is the Program Number

S S is the Segment Number (01 to 16)

* is the End of Message character (Hex 2A)

No space characters are permitted in messages. Any syntax errors in a received message will cause the slave controller to issue no reply and await the Start of Message character.

Table 5-1 {DATA} Element - Sign/Decimal Point Position

{DATA} Content	Data Format	{DATA} Content	Data Format
abcd0	+abcd	abcd5	-abcd
abcd1	+abc.d	abcd6	-abc.d
abcd2	+ab.cd	abcd7	-ab.cd
abcd3	+a.bcd	abcd8	-a.bcd

5.4.1 Type 1 Message

L {N} ? ? *

This message is used by the master device to determine whether the addressed slave Setpoint Programmer is active. The reply from an active slave is

L {N} ? A *

An inactive Setpoint Programmer will give no reply.

5.4.2 Type 2 Message

L {N} {P} {C} * or R {N} {P} {C} *

This type of message is used by the master device to interrogate or modify a parameter in the addressed Setpoint Programmer. {P} identifies the parameter - as defined in Table 5-2 (Programmer Parameters) or Table 5-4 (Controller Parameters) - and {C} represents the command to be executed, which may be one of the following:

- + (Hex 2B) - Increment the value of the parameter defined by {P}
- (Hex 2D) - Decrement the value of the parameter defined by {P}
- ? (Hex 3F) - Determine the current value of the parameter defined by {P}

The reply from the addressed Setpoint Programmer is of the form:

L {N} {P} {DATA} A * or R {N} {P} {DATA} A *

where {DATA} comprises five ASCII-coded digits whose format is shown in Table 5-1. The data is the value requested in a query message or the new value of the parameter after modification. If the action requested by the message from the master device would result in an invalid value for that parameter (either because the requested new value would be outside the permitted range for that parameter or because the parameter is not modifiable), the Setpoint Programmer replies with a negative acknowledgement:

L {N} {P} {DATA} N * or R {N} {P} {DATA} N *

The {DATA} string in the negative acknowledgement reply will be indeterminate. If the process variable or the deviation is interrogated whilst the process variable is outside the range of the Setpoint Programmer, the reply is:

L {N} {P} < ? ? > 0 A *

if the process variable is over-range, or

L {N} {P} < ? ? > 5 A *

if the process variable is under-range.

Scan Tables

A parameter identifier character "]" in the message from the master device indicates that a "Scan Table" operation is required. This provides a facility for interrogating the values of a group of parameters and status in a single message from the master device. The reply to such a command would be in the form:

$$L \{N\}] xx aaaaa bbbbb ccccc ddddd eeeee A *$$

for Controller Scan Table, or

$$R \{N\}] 25 P ss WWW TTT CCCC SSSS EEEE A *$$

for a Program Scan Table. For the Controller Scan Table response, xx is the number of data digits to follow; this is 20 for a single-control-output instrument and 25 for a dual-control-output instrument. For further information, refer to Subsections 5.11 and 5.16.

5.4.3 Type 3 Message

$$L \{N\} \{P\} \# \{DATA\} * \text{ or } R \{N\} \{P\} \# \{DATA\} *$$

This message type is used by the master device to set a parameter to the value specified in {DATA}. The command is not implemented immediately by the slave Setpoint Programmer; the slave will receive this command and will then wait for a Type 4 message (see below). Upon receipt of a Type 3 message, if the {DATA} content and the specified parameter are valid, the slave Setpoint Programmer reply is of the form:

$$L \{N\} \{P\} \{DATA\} I * \text{ or } R \{N\} \{P\} \{DATA\} I *$$

(where I = Hex 49) indicating that the Setpoint Programmer is ready to implement the command. If the parameter specified is invalid or is not modifiable or if the desired value is outside the permitted range for that parameter, the Setpoint Programmer replies with a negative acknowledgement in the form:

$$L \{N\} \{P\} \{DATA\} N * \text{ or } R \{N\} \{P\} \{DATA\} N *$$

5.4.4 Type 4 Message

$$L \{N\} \{P\} I * \text{ or } R \{N\} \{P\} I *$$

This type of message is sent by the master device to the addressed slave Setpoint Programmer following a successful Type 3 transaction with the same slave Setpoint Programmer. Provided that the {DATA} content and the parameter specified in the preceding Type 3 message are still valid, the slave Setpoint Programmer will then set the parameter to the desired value and will reply in the form:

L {N} {P} {DATA} A *

or

R {N} {P} {DATA} A *

where {DATA} is the new value of the parameter. If the new value or parameter specified is invalid, the slave Setpoint Programmer will reply with a negative acknowledgement in the form:

L {N} {P} {DATA} N *

or

R {N} {P} {DATA} N *

where {DATA} is indeterminate. If the immediately-preceding message received by the slave Setpoint Programmer was not a Type 3 message, the Type 4 message is ignored.

5.5 PROGRAMMER PARAMETERS (Start of Message character = R)

The Programmer Parameters and their identifier characters are listed in Table 5-2 and their functions are shown in Table 5-3.

Unless otherwise stated, the {DATA} element will follow the standard five-digit format and the decimal point position must be correct for the new value to be accepted and for modification to occur.

Table 5-2 Programmer Parameters and Identifiers

Identifier	Parameter/Command	Comments	Type
A	Segment Number	Selects segment in selected program	Read/Write
B	Final Setpoint Value	In selected segment	Read/Write
C	Segment Time/Ramp Rate	In selected segment	Read/Write
G	Number of Cycles Programmed	For selected program	Read/Write
H	Number of Cycles Completed	For selected program	Read Only
I	Current Segment Number	In currently-running/held program	Read Only
J	Segment Time Remaining	In currently-running segment	Read Only
K	Programmer Commands	Program control/selection	Write Only
L	Programmer Status 1	Summary of Programmer Parameters	Read Only
M	Current Setpoint Value	In currently-running/held program	Read Only
N	Current Segment Event Status	Status of each of four Events	Read Only
P	Current Program Number	Indicates program currently running/held	Read Only
Q	Delay	Defines delay to start of all programm	Read/Write

Identifier	Parameter/Command	Comments	Type
R	Preset x60 Mode	ON, OFF or not selected (for selected program only)	Read/Write
S	Power Failure Recovery	Selects Cold Start or Warm Start recovery	Read/Write
T	Program Number	Selects program for comms operations	Read/Write
U	User Program Tags	Defines tag name for a program	Read/Write
V	Hold Band value	In selected program	Read/Write
W	Hold Time value	Time in Manual Hold	Read Only
X	Auto-Hold type	Selects Auto-Hold operation	Read/Write
Y	Hold On	Ramps only, Dwells only or both	Read/Write
[External Selection Control	Enables/disables external program selection and/or Run/Hold/Abort control	Read/Write
\	Segment Definitions	Reads/defines details of stated program/segment	Read/Write
]	Program Scan Table	Reads summary of stated program/segment	Read Only
_	Segment Mode	Time Mode or Rate Mode	Read/Write
'	Programmer Status 2	Summary of Programmer Parameters	Read Only

Table 5-3 Programmer Parameters - Functions

Parameter	Five-digit {DATA} Element		Dependent Upon:
	Adjustment Range	Decimal Point Position	
Segment Number	0001 to 0016	0	Program Number
Final Setpoint Value	Input Range Min. - Input Range Max.	As per input	Program Number; Segment Number
Segment Time/Ramp Rate	Time Mode: 0000 - 9959 (2 right-most digits must not exceed 59) Rate Mode: 0000 - 9999 000n = Join to Program n (n = 1 to 8) 0009 = Repeat Segment 0010 = End Segment	2 As per input 5 5 5	Program Number; Segment Number
Number of Cycles Programmed	0000 (infinite) - 9999	0	Program Number
Number of Cycles Completed	Read Only; value range 0000 - 9999 and <HH>0 (numeric limit exceeded)	0	Current Program Number
Current Segment Number	Read Only; value range 0001 - 0016	0	Current Program Number
Segment Time Remaining	Read Only; value range 0000 - 9959 (2 right-most digits must not exceed 59) and <HH>2 (numeric limit exceeded)	2	Current Program Number; Current Segment Number

Parameter	Five-digit {DATA} Element		Dependent Upon:
	Adjustment Range	Decimal Point Position	
Programmer Commands	Write Only; value range 0001 - 0013, 0021 - 0028 (see Subsection 5.6)	0	-
Programmer Status 1	Read Only (see Subsection 5.7)	N/A	-
Current Setpoint Value	Read Only	As per input	-
Current Segment Event Status	Read Only (see Subsection 5.8)	N/A	Current Segment Number; Current Program Number
Current Program Number	Read Only; value range 0001 - 0008	0	-
Delay (<i>all programs</i>)	0000 - 9959 (2 right-most digits must not exceed 59)	2	-
Preset x60 Mode	0000 = No preset state 0001 = Preset x60 ON 0002 = Preset x60 OFF	0	Program Number
Power Fail Recovery	0000 = Cold Start 0001 = Warm Start (see Subsection 5.9)	0	-
Program Number	0001 - 0008	0	-
User Tag Names	See Subsection 5.14	-	Program Number
Hold Band	0000 - input span	As per input	Program Number
Hold Time	Read Only; value range 0000 - 9959 (2 right-most digits must not exceed 59) and <HH>2 (numeric limit exceeded)	2	Current Program Number
Auto-Hold Type	0000 = OFF 0001 = only on PV above SP 0002 = only on PV below SP 0003 = on both	0	Program Number
Hold On	0000 = Ramps and Dwells 0001 = Dwells only 0002 = Ramps only	0	Program Number
External Selection Control (<i>all programs</i>)	0000 = disabled 0001 = program selection only 0002 = Run/Hold/Abort control only 0003 = both	0	-
Program/Segment Definitions	See Subsection 5.10		-
Program Scan Table	Read Only (see Subsection 5.11)		-
Segment Mode	0000 = Time; 0001 = Rate	0	-
Programmer Status 2	Read Only (see Subsection 5.13)	N/A	-

5.6 PROGRAMMER COMMANDS

{P} = K

This Write Only parameter is used to convey commands to be implemented by the Setpoint Programmer. In the {DATA} element, the decimal point position digit is set to 0; the remaining four digits are used to specify the command to be executed:

Value	Command	Value	Command
0001	Run currently-selected program ^{1,2}	0011	Disable x60 Mode
0002	Manually hold currently-running program ¹	0012	Enable Program Lock
0003	Release Manual Hold ¹	0013	Diabile Program Lock
0004	Jump forward one segment ²	0021	Run Program 1 ^{1,2,3}
0005	Abort currently-running program ¹	0022	Run Program 2 ^{1,2,3}
0006	Start on Controller Setpoint	0023	Run Program 3 ^{1,2,3}
0007	Start on Process Variable	0024	Run Program 4 ^{1,2,3}
0008	End on Controller Setpoint	0025	Run Program 5 ^{1,2,3}
0009	End on Final Value	0026	Run Program 6 ^{1,2,3}
0010	Enable x60 Mode	0027	Run Program 7 ^{1,2,3}
		0028	Run Program 8 ^{1,2,3}

- 1. If External Run/Hold/Abort Control is active, a negative acknowledgement (NAK) is returned.
- 2. If program is in Manual Hold, a negative acknowledgement (NAK) is returned.
- 3. If External Program Selection is active, a negative acknowledgement (NAK) is returned.

5.7 PROGRAMMER STATUS 1

{P} = L

This command obtains status information from the Setpoint Programmer. The {DATA} element in the response is a five-digit decimal number which, when converted into binary form, indicates status as follows:

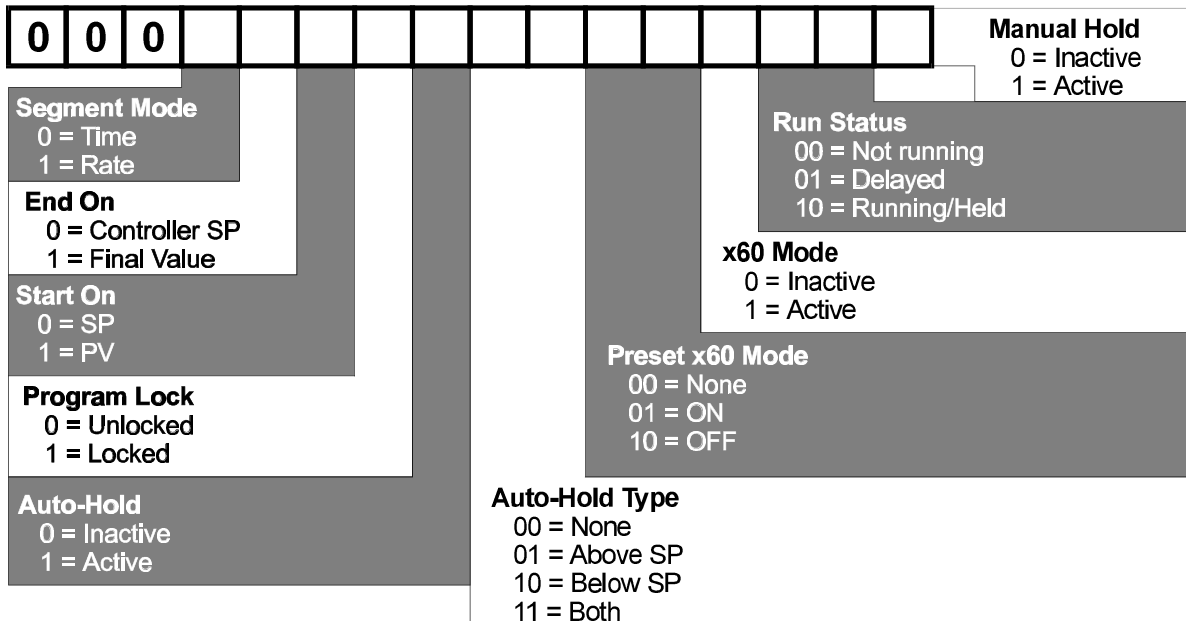

5.8 CURRENT SEGMENT EVENT STATUS

{P} = N

This Type 2 interrogation message returns the status of the four event outputs for the currently-executed segment (as defined by Current Segment Number and Current Program Number). The {DATA} element has six digits; the first two are 04 and each of the remaining digits (Event 1 being represented by the left-most digit etc.) may be 1 (active) or 0 (inactive).

5.9 POWER FAIL RECOVERY

{P} = S

This parameter defines the mode of recovery on restoration of power after a power failure. The {DATA} element decimal point position digit will be set to 0 and the remaining four digits will be set to either 0000 (Execute Cold Start -entry into Base Mode with Program Number set as when power failed and Segment Number blank) or 0001 (Execute Warm Start - program resumed from point when power failed). Any attempt to set these digits to a value outside this range will cause a negative acknowledgement (NAK) to be returned.

5.10 PROGRAM/SEGMENT DEFINITIONS

{P} = \

This parameter provides a single-message method of setting a given segment in a given program to a pre-defined state and of reading segment details without reference to the Program Number and Segment Number parameters. It is interrogated using a Type 5 message. The normal response to interrogation is of the form:

$$R\{N\}\14PSSFFFFFFTTTTEA^*$$

where:

- {N} is the communications address (01 - 32 or 1 - 32)
- 14 is the character count for the following data
- P is the program number
- SS is the segment number
- FFFFF is the Final Setpoint Value
- TTTT is the Segment Time or Rate (as appropriate)
- E is a single-character hexadecimal representation of the segment's Event State.

If the Program Number or Segment Number is out of range, a negative response will be returned in the form:

$$R\{N\}\14PSSFFFFFFTTTTEA^*$$

A specified segment may have details written to it by means of a Type 3/5 message sequence.

Type 3 Message:	R{N}\#14PSSFFFFFFTTTTTE*	
Reply:	R{N}\14PSSFFFFFFTTTTTEI*	(positive acknowledgement)
	R{N}\14PSSFFFFFFTTTTTEN*	(negative acknowledgement)
Type 5 Message:	Raa\PSSI*	
Reply:	Raa\14PSSFFFFFFTTTTTEA*	(positive acknowledgement)
	Raa\14PSSFFFFFFTTTTTEN*	(negative acknowledgement)

5.11 PROGRAM SCAN TABLE

{P} =]

This Read Only parameter may be interrogated using a Type 2 message. The normal response is of the form:

R {N}] 25 P s s V V V V T T T T C C C C S S S S E E E E A *

where:	{N}	is the comms address of the Setpoint Programmer
	P	is the Program Number
	ss	is the Segment Number
	VVVV	is the current setpoint value
	TTTT	is the Time Remaining/Hold Time (decimal position 2 assumed)
	CCCC	is the number of cycles completed (0000 to 9999; if higher, will be set to <HH>, signifying "over-range"); decimal point 0 assumed
	SSSS	is the Programmer Status 1 (see Subsection 5.7)
	EEEE	is the Event Status; each digit (Event 1 being represented by the left-most digit etc.) is 1 (active) or 0 (inactive).

5.12 SEGMENT MODE

{P} = _

This parameter controls the overall programming algorithm of the instrument; Time Mode or Rate Mode. Changing this parameter will cause all other Program Definitions to be set to default values, which takes in excess of one second to

complete. Software which writes to this parameter must therefore take this time into account before expecting a reply.

5.13 PROGRAMMER STATUS 2

{P} = ‘

This Read Only parameter gives a bit map representing the current status of the Event Output and Program Control Input ports. It is interrogated by a Type 2 message only and the response is in the normal five-digit {DATA} format which contains a decimal representation (decimal point position is always set to 0) of an eight-bit binary number whose bits have the following significance:

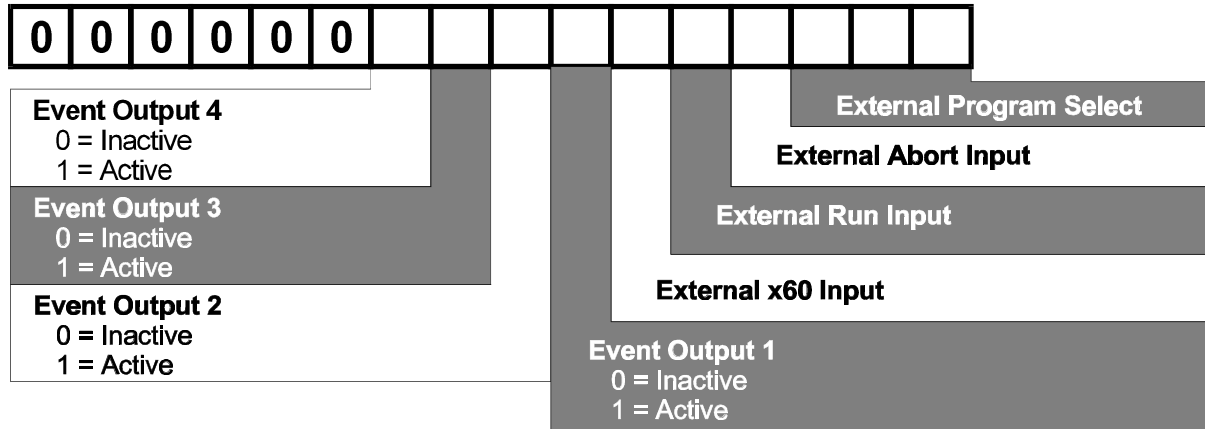

5.14 USER TAG NAMES

Tag names may use all alphanumeric characters, spaces and standard punctuation marks. They must consist of eight characters, with blanks being represented by space characters.

The interrogation message is the Type 2 message:

Query: R {N} U ? *
Reply: R {N} U 08 CCCCCCCC A *

The tag names can be written with the usual Type 3/Type 4 message transaction:

Type 3 Message: R {N} U # 08 CCCCCCCC *
Reply: R {N} U 08 CCCCCCCC I * (Positive acknowledgement)
R {N} U 08 CCCCCCCC N * (Negative

acknowledgement)

Type 4 Message: R {N} U I *
Reply: R {N} U 08 CCCCCCCC A *

5.15 CONTROLLER PARAMETERS (Start of Message character = L)

The controller parameters and their identifier characters are listed in Table 5-4 and their functions are listed in Table 5-5.

Table 5-4 Controller Parameters and Identifiers

Identifier	Parameter/Command	Comments	Type
A	Setpoint High Limit	Maximum setpoint value	Read/Write
B	Output 1 Power Limit *	Safety power limit	Read/Write
C	Alarm 1 value	Alarm 1 active at this level	Read/Write
D	Rate ¹	Derivative Time Constant value	Read/Write
E	Alarm 2 Value	Alarm 2 active at this level	Read/Write
F	ON/OFF Differential Value *	Switching hysteresis for ON/OFF control	Read/Write
G	Scale Range Maximum	Upper limit of scaled input range	Read/Write
H	Scale Range Minimum	Lower limit of scaled input range	Read/Write
I	Reset Value ¹ or Loop Alarm Time	Integral Time Constant value or (for ON/OFF control with Loop Alarm Enabled) Loop Alarm Time value	Read/Write
J	Manual Reset *	Bias value	Read/Write
K	Overlap/Deadband Value *	Portion of PB1 + PB2 over which both outputs are active	Read/Write
L	Controller Status ²	Status information (see NOTES ON TABLE 5-4)	Read Only
M	Process Variable Value	Universal input	Read Only
N	Output 1 Cycle Time * Motor Travel Time †	Used to maximise relay life Time for valve to travel full range of movement (from one stop to the other)	Read/Write Read/Write
O	Output 2 Cycle Time * Minimum Motor ON Time †	Used to maximise relay life Minimum drive effort to initiate movement of stationary valve.	Read/Write Read/Write
P	Proportional Band 1 (PB1) Value ¹	Proportion of input span over which Output 1 level is proportional to the PV level	Read/Write
Q	Scale Range Decimal Point Position	Decimal point position	Read/Write
S	Setpoint Value	-	Read/Write
T	Setpoint Low Limit	Minimum value of setpoint	Read/Write
U	Proportional Band 2 (PB2) Value ¹	Proportion of input span over which Output 2 level is proportional to the PV level	Read/Write
V	Deviation Value	PV - SP	Read Only
W	Output Power *	Output power level	Read Only
Z	Setpoint Programmer Commands ³	See NOTES ON TABLE 5-4	Write Only

Identifier	Parameter/Command	Comments	Type
[Recorder Output Scale Maximum	Maximum scale value for recorder output - corresponds to Input Scale Maximum	Read/Write
\	Recorder Output Scale Minimum	Minimum scale value for recorder output - corresponds to Input Scale Minimum	Read/Write
]	Scan Table	Reads main controller parameters	Read Only
m	Input Filter Time Constant	Digital filter	Read/Write
v	Process Variable Offset Value	Modified PV = Actual PV - PV Offset	Read/Write

* Not applicable to VMD Output.

† Applicable only to VMD Output

NOTES ON TABLE 5-4

- These parameters cannot be modified whilst either the Pre-Tune facility or the Self-Tune facility is activated.
- The Controller Status Byte has the following format:

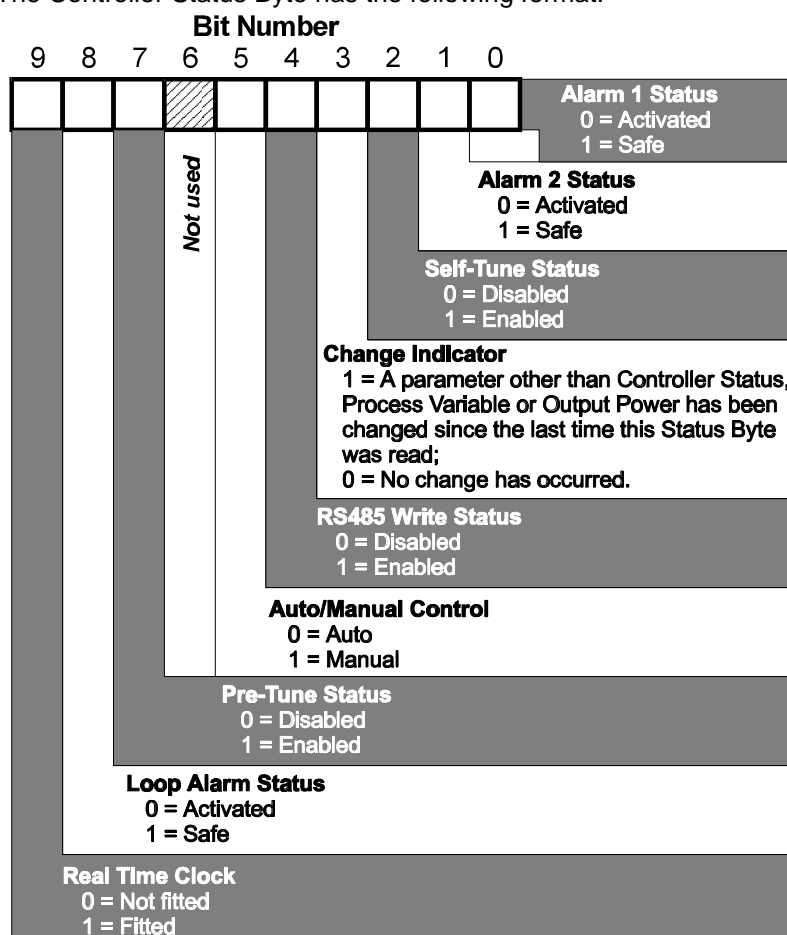

- Only Type 3 or Type 4 Messages are allowed with this parameter. In the Type 3 Message, the {DATA} field must be one of eight five-digit numbers. The reply from the Setpoint Programmer also contains the {DATA} field with the same content. When the master device issues the Type 4 Message, the setpoint Programmer responds with the same {DATA} field content. The commands corresponding to the {DATA} field value are:

00010 = Activate Manual Control
 00020 = Activate Automatic Control
 00030 = Activate the Self-Tune facility
 00040 = De-activate the Self-Tune facility
 00050 = Request Pre-Tune (see note below)
 00060 = Abort Pre-Tune
 00130 = Activate Loop Alarm
 00140 = De-activate Loop Alarm

NOTE: The Setpoint Programmer will go into Pre-Tune Mode only if the process variable is at least 5% of input span from the setpoint.

Table 5-5 Controller Parameters - Functions

Parameter	Five-digit {DATA} Element		Default Value
	Adjustment Range	Decimal Point Position	
INPUT PARAMETERS			
Process Variable (PV) ²	None - Read Only	As per input	N/A
Process Variable Offset ³	Modified PV limited by Scale Range Max. and Scale Range Min.	As per input	0
Scale Range Maximum ¹		As per input	1000
Scale Range Minimum ¹		As per input	0000
Scale Range Decimal Point Position ¹	0 = xxxx 1 = xxx.x 2 = xx.xx 3 = x.xxx	0	1
Filter Time Constant	0.0 secs. to 100.0 secs.	1	2.0 secs
OUTPUT PARAMETERS			
Power Output Value ⁴	0% to 100% for one output; -100% to +100% for two outputs	0	-
Output 1 Power Limit ⁸	0% to 100%	0	100%
Output 1 Cycle Time	Powers of 2 in the range 0.5secs. to 512secs. (0.5, 1, 2, 4 etc.)	0 or 1	32secs.
Output 2 Cycle Time	Powers of 2 in the range 0.5secs. to 512secs. (0.5, 1, 2, 4 etc.)	0 or 1	32secs.
Recorder Output Scale Maximum Value	-1999 to 9999	As per input	Scale Range Max.
Recorder Output Scale Minimum Value	-1999 to 9999	As per input	Scale Range Min.
SETPOINT PARAMETERS			
Setpoint (SP) Value	Setpoint Low Limit to Setpoint High Limit	As per input	-
Setpoint (SP) High Limit	Current SP to Input Range Maximum	As per input	Input Range Max.
Setpoint (SP) Low Limit	Input Range Minimum to current SP	As per input	Input Range Min.
ALARM PARAMETERS			
Alarm 1 Value	Depends upon type ⁵	As per input	As per type ⁵
Alarm 2 Value	Depends upon type ⁵	As per input	As per type ⁵

Parameter	Five-digit {DATA} Element		Default Value
	Adjustment Range	Decimal Point Position	
TUNING PARAMETERS			
Rate ⁸	00secs. to 99mins. 59secs. ⁶	2	1min. 15secs.
Reset ⁸	1sec. to 99mins. 59secs. ⁶	2	5mins. 00secs.
Manual Reset (Bias) ⁸	0% to 100% for one output; -100% to +100% for two outputs	0 (positive) or 5 (negative)	25%
ON/OFF Differential	0.1% to 10.0% of input span	1	0.5%
Overlap/Deadband ^{7,8}	-20% to +20% of PB1 + PB2; negative = Deadband positive = Overlap	0 (positive) or 5 (negative)	0%
Proportional Band 1 (PB1)	0.0% to 999.9% of input span	1	10.0%
Proportional Band 2 (PB1) ^{7,8}	0.0% to 999.9% of input span	1	10.0%
STATUS PARAMETERS			
Controller Status (see Table 5-4)	Read Only - not adjustable	N/A	N/A
Arithmetic Deviation	Read Only - not adjustable	As per input	N/A
Controller Scan Tables (see Subsection 5.16)	Read Only - not adjustable	N/A	N/A

NOTES ON TABLE 5-5

1. Applicable to DC linear inputs only.
2. If the process variable is out of range, the {DATA} byte in the reply will be <??>0 (over-range) or <??>5 (under-range).
3. The Process Variable Offset parameter value should be selected with care. Injudicious application of values could lead to the displayed process variable value bearing no meaning relationship to the actual process variable value.
4. If Manual Control is not selected, this is a Read Only parameter (i.e. cannot be adjusted).
5. The default settings for the different alarm types are as follows:

Alarm Type	Adjustment Range	Default Setting
Process High	Scale Range Min. to Scale Range Max.	Scale Range Max.
Process Low	Scale Range Min. to Scale Range Max.	Scale Range Min.
Band	0 to input span from SP	5 input units
Deviation	±input span from SP	5 input units

6. {DATA} element is in the form mm.ss (mm = minutes, ss = seconds).
7. Applicable only if Output 2 is fitted.
8. Not operative if Proportional Band = 0.

5.16 CONTROLLER SCAN TABLE

The Controller Scan Table operation takes the form of a Type 2 interrogation command which accesses a set of information (held in the {DATA} element in the response). The response would be in the form:

L {N}] xx aaaaa bbbbb ccccc ddddd eeeee A *

where xx is the number of data digits in the {DATA} element to follow; this is 20 for a single-control-output instrument and 25 for a dual-control-output instrument. These digits are as described in Table 5-1 and may comprise:

aaaaa	The current setpoint value
bbbbb	The current process variable value
ccccc	The current value of Output 1 Power (0 - 100%)
dddd	The current value of Output 2 Power (0 - 100%), if applicable.
eeee	The Controller Status (see Note 2 on Table 5-4).

5.17 ERROR RESPONSE

The circumstances under which a message received from the master device is ignored are:

- Parity error detected
- Syntax error detected
- Timeout elapsed
- Receipt of a Type 4 message without a preceding Type 3 command message.

Negative acknowledgements will be returned if, in spite of the received message being notionally correct, the Setpoint Programmer cannot supply the requested information or perform the requested operation. The {DATA} element of a negative acknowledgement will be indeterminate.

5.18 MASTER COMMUNICATIONS MODE

When the Setpoint Programmer is set to operate as the master device over an RS485 communications link to up to 99 slave instruments (see Subsection 4.2), it uses the ASCII communications protocol to send the current setpoint value to each slave instrument connected and powered-up. The Setpoint Programmer will detect all addresses which have no slave instrument and will automatically skip to the next address; the Setpoint Programmer periodically interrogates "empty" addresses to determine whether or not they have become active. The address-to-address scan rate is five per second at 4800 Baud and ten per second at 9600 Baud.

SECTION 6

MODBUS RTU SERIAL COMMUNICATIONS

The Setpoint Programmer may be equipped with two-wire RS485-compatible serial communications, by which means communication may occur between the Setpoint Programmer and a master device (e.g. a computer or terminal).

6.1 COMMUNICATIONS WRITE ENABLE/DISABLE

When Communications Write operations are enabled (in Controller Define Mode - see Operator's Manual, Section 9), the Setpoint Programmer parameters may be adjusted by the master device via the serial communications link. If communications Writes are disabled, the Setpoint Programmer will not adjust or change any parameters in response to commands received from the master device and will send a negative acknowledgement in response to such commands. Whether communications Writes are enabled or disabled, the Setpoint Programmer will return the requested information in response to interrogation from the master device.

6.2 PHYSICAL REQUIREMENTS

6.2.1 Character Transmission

The data format is fixed to be one start bit, eight data bits and one stop bit. The Baud rate may be selected to be 1200, 2400, 4800 (default) or 9600 Baud. The parity is selectable to be even, odd, or none.

6.2.2 Line Turn-round

The line turn-round timings adhere to the industry standard.

6.3 MODBUS RTU PROTOCOL

The RS485 Communications Option can be set to use the industry standard MODBUS protocol. The following restrictions are imposed:

Baud rates may be set to 1200, 2400, 4800 or 9600 Baud only.

Support for multi-parameter Write operations is limited to support of the Multi-Word Write Function (Number 16) but permits writing of one parameter only per message.

The multi-parameter Read operations support a maximum of 10 parameters per message.

The following MODBUS functions are supported (JBUS names, where applicable, are given in italics):

Function	MODBUS Function No.
Read Coil Status (<i>Read n Bits</i>)	01/02
Read Holding Registers (<i>Read n Words</i>)	03/04
Force Single Coil (<i>Write 1 Bit</i>)	05
Preset Single Register (<i>Write 1 Word</i>)	06
Loopback Diagnostic Test	08
Preset Multiple Registers (<i>Write n Words</i>)	16

The Setpoint Programmer will identify itself in response to a Read Holding Registers message which enquires the values of word parameters 121 and 122 (see Table 6-2); MODBUS Function 17 (Report Slave ID) is not supported.

6.3.1 Message Formats

The first character of every message is the Setpoint Programmer address, in the range 1 - 255 and 0 for broadcast messages. The second character is always the Function Number. The contents of the remainder of the message depends upon this Function Number.

In most cases the Setpoint Programmer is required to reply to the message by echoing the address and Function Number, together with an echo of all or part of the message received (in the case of a request to write a value or carry out a command) or the information requested (in the case of a Read Parameter operation). Broadcast messages are supported at address 0 (to which the Setpoint Programmer responds by taking some action *without sending back any reply*).

Data is transmitted as eight-bit binary bytes with one start bit, one stop bit and optional parity checking (none, even or odd). A message is terminated simply by a delay of more than three character lengths at the Baud rate used; any character received after such a delay is considered to be the potential address at the start of a new message.

Since only the RTU form of the protocol is supported, each message is followed by a two-byte CRC 16 (a 16-bit cyclic redundancy checksum). This checksum is calculated in accordance with a formula which involves recursive division of the data by a polynomial, with the input to each division being the remainder of the results of the previous division. The dividing polynomial is

$$2^{16} + 2^{15} + 2^2 + 1 \text{ (Hex 18005)}$$

but this is modified in two ways:

- (a) because the bit order is reversed, the binary pattern is also reversed, making the most significant bit (MSB) the right-most bit, and

(b) because only the remainder is of interest, the right-most (most significant) bit can be discarded.

Thus, the polynomial has the value Hex A001. The CRC algorithm is shown in Figure 6-1.

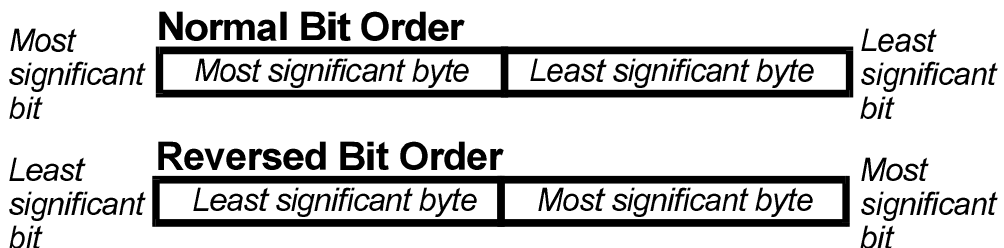
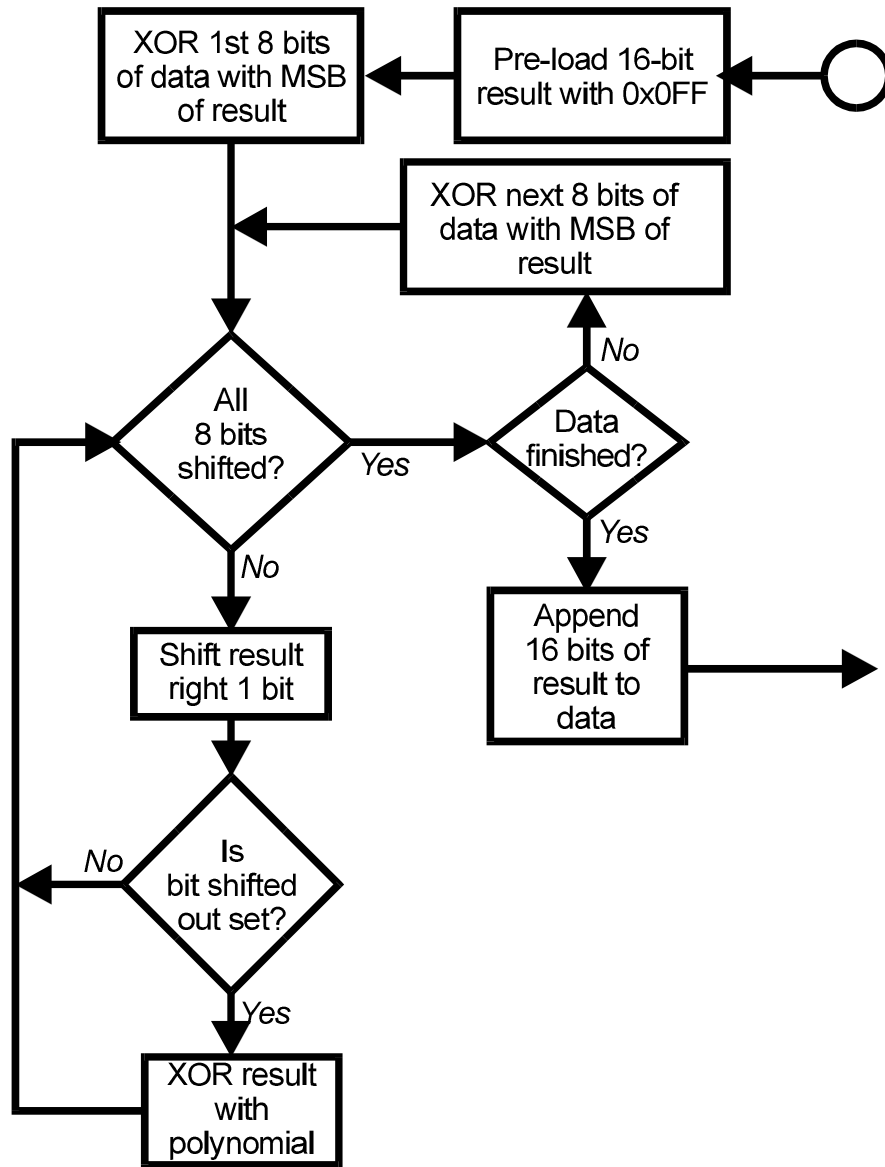

REVERSED BIT ORDER USED

Figure 6-1 Cyclic Redundancy Checksum Algorithm

Read Coil Status (Read n Bits) - 01/02

The message sent to the Setpoint Programmer consists of eight bytes:

Addr.	Func.	Addr. of 1st Bit		No. of Bits		CRC 16	
	1 or 2	HI	LO	HI	LO	HI	LO

The normal reply will echo the first two characters of the message received followed by a single-byte data byte count (which will not include itself or the CRC). For this message, there will be one byte of data per eight bits-worth of information requested, with the least significant bit of the first data byte transmitted depicting the state of the lowest-numbered bit required.

Addr.	Func.	Count	1 - 8	9 - 16	17 - 24	...	Last	CRC 16	
	1 or 2							HI	LO

This function is used mostly to report Setpoint Programmer status information; thus, a bit set to 1 indicates that the corresponding feature is currently active/enabled and a bit set to 0 indicates that the corresponding feature is currently inactive/disabled.

If an exact multiple of eight bits is not requested, the data padding with trailing zeros is used to preserve the eight-bit format. After the data has been transmitted, the CRC16 value is sent.

Read Holding Registers (Read n Words) - 03/04

The message sent to the Setpoint Programmer to obtain the value of one or more registers comprises the following eight bytes:

Addr.	Func.	Addr. of 1st Word		No. of Words		CRC 16	
	3 or 4	HI	LO	HI	LO	HI	LO

The normal reply will echo the first two characters of the message received followed by a single-byte data byte count (which will not include itself or the CRC). The count value equals the number of parameter values read multiplied by two. Following the byte count, the specified number of parameter values are transmitted, followed by the CRC16 bytes:

Addr.	Func.	Count	1st Value		Last Value		CRC 16	
	3 or 4		HI	LO	HI	LO	HI	LO

Force Single Coil (Write 1 Bit) - 05

The message received by the Setpoint Programmer is eight bytes long, comprising the standard pre-amble and the address of the bit to be forced, followed by a two-byte word whose most significant byte contains the desired truth value of the bit expressed as 0xFF (TRUE) or 0x00 (FALSE):

Normally, this function is used to control such features as Auto-Manual Control selection and tuning (Pre-Tune, Self-Tune). The normal reply sent by the Setpoint

Addr.	Func.	Addr. of Bit		State		CRC 16	
	5	HI	LO	FF/00	0	HI	LO

Programmer will be a byte-for-byte echo of the message received.

Preset Single Register (*Write 1 Word*) - 06

The message sent to the Setpoint Programmer comprises eight bytes: the address and Function Number (as usual), the address of the parameter to be written, the two-byte value to which the parameter is to be set and the CRC16 bytes:

The normal response from the Setpoint Programmer is a complete echo of the

Addr.	Func.	Addr. of Word		Value		CRC 16	
	6	HI	LO	HI	LO	HI	LO

received message.

Loopback Diagnostic Test - 08

This is an eight-byte message comprising the usual pre-amble, a two-byte diagnostic code, two bytes of data and the CRC16 bytes:

Addr.	Func.	Diagnostic Code		Value		CRC 16	
	8	0	0	HI	LO	HI	LO

The only diagnostic code supported is 00. The normal response is an exact echo of the received message.

Preset Multiple Registers (*Write n Words*) - 16

This is an eleven-byte message. only one parameter may be written for each received message. The usual pre-amble is followed by the address of the parameter to be written, a two-byte word count (always set to 1), a single-byte byte count (always set to 2), the value to be written and the CRC16 bytes:

Addr.	Func.	Addr. of Word		No. of Words		Count	Value		CRC 16	
	16	HI	LO	0	1	2	HI	LO	HI	LO

The Setpoint Programmer normally responds with the following eight-bit reply:

Addr.	Func.	Addr. of Word		No. of Words		CRC 16	
	16	HI	LO	0	1	HI	LO

6.3.2 Error and Exception Responses

If a received message contains a corrupted character (parity check failure, framing error etc.) or if the CRC16 check fails, or if the received message is otherwise syntactically flawed (e.g. byte count or word count is incorrect), the Setpoint Programmer will ignore that message.

If the received message is syntactically correct but nonetheless contains an illegal value, the Setpoint Programmer will send a five-byte exception response as follows:

Addr.	Func.	Exception No.	CRC 16	
			HI	LO

The Function Number byte contains the function number contained in the message which caused the error, with its top bit set (i.e. Function 3 becomes 0x83) and the Exception Number is one of the following codes:

Code	Name	Cause
1	ILLEGAL FUNCTION	Function Number out of range
2	ILLEGAL DATA ADDRESS	Parameter ID out of range or not supported
3	ILLEGAL DATA VALUE	Attempt to write invalid data/required action not executed
4	DEVICE FAILURE	N/A
5	ACKNOWLEDGE	N/A
6	BUSY	N/A
7	NEGATIVE ACKNOWLEDGE	N/A

For error and exception responses specific to a parameter, see notes in Table 6-1 and Table 6-2.

NOTE: Writing a parameter value equal to its current value is a valid transaction; this will not cause an error response.

6.3.3 Address Range

The selectable address range is 1 - 255. The Setpoint Programmer will respond appropriately to Address 0 - broadcast messages - no matter what address is selected.

NOTE: The total receiver load on the RS485 link *must not exceed 32 standard RS485 unit loads*. This applies to both standard and enhanced RS485 communications. A Setpoint Programmer presents $\frac{1}{4}$ standard RS485 load, so a maximum of 128 Setpoint Programmers are permitted. With other devices connected, the limit is dictated by the sum total of all the RS485 receiver loadings.

6.3.4 Bit Parameters

The bit parameters (Controller Status) are shown in Table 6-1.

6.3.5 Word Parameters

The word parameters are shown in Table 6-2.

Table 6-1 Bit Parameters

Parameter	No.	Notes
Communications Write Status	1	Read Only; 1 = Write Enabled, 0 = Write Disabled
Auto/Manual Control	2	1 = Manual Control, 0 = Auto Control
Self-Tune	3	1 = Activate(d), 0 = Dis-engage(d)
Pre-Tune ¹	4	1 = Activate(d), 0 = Dis-engage(d)
Alarm 1 Status	5	Read Only; 1 = Active, 0 = Inactive
Alarm 2 Status	6	Read Only; 1 = Active, 0 = Inactive
Auto Pre-Tune	7	1 = Enable(d), 0 = Disable(d)
Parameter Changed ²	8	Read Only; 1 = Change, 0 = No change
Loop Alarm Status	9	1 = Active/Enable, 0 = Inactive/Disable
Reserved	10 - 16	

NOTES

1. Any attempt to activate Pre-Tune will fail if the process variable is within 5% of input span from the setpoint.
2. This indicates whether a parameter has been changed from the front panel since the last interrogation via the communications link. Every interrogation of the **Parameter Changed** bit resets it to 0.

Table 6-2 Word Parameters

Parameter	No.	Notes
CONTROLLER DATA		
Process Variable	1	Read Only
Setpoint	2	
Output Power	3	Read Only if in Auto Control Mode
Arithmetic Deviation	4	Read Only
Proportional Band 2	5	Only applicable if Output 2 is fitted
Proportional Band 1	6	
Controller Status	7	Read Only (see Table 6-1)
Reset (Integral Time Constant) or Loop Alarm Time	8	Integral Time Constant value or (for ON/OFF control with Loop Alarm enabled) Loop Alarm Time
Rate (Derivative Time Constant)	9	
Output 1 Cycle Time	10	
Scale Range Low	11	Read Only
Scale Range High	12	Read Only
Alarm 1 Value	13	
Alarm 2 Value	14	
Manual Reset (Bias)	15	
Overlap/Deadband	16	
ON/OFF Differential	17	
Decimal Point Position	18	Read Only
Output 2 Cycle Time	19	
Output 1 Power Limit	20	
Reserved	21	
Setpoint High Limit	22	
Setpoint Low Limit	23	
Input Filter Time Constant	24	
Process Variable Offset	25	
Recorder Output Maximum	26	
Recorder Output Minimum	27	
Alarm 1 Hysteresis	28	
Alarm 2 Hysteresis	29	
Motor Travel Time	30	
Minimum Motor ON Time	31	
PROGRAMMER DATA		
Segment Mode	32	Time Mode or Rate Mode - see Subsection 6.6
Programmer Status Byte 1	33	Read Only - see Subsection 6.5
Programmer Status Byte 2	34	Read Only - see Subsection 6.7
Current Program Number	35	Read Only - indicates current program running/held
Current Segment Number	36	Read Only - in current running/held program
Current Setpoint Value	37	Read Only
Current Segment Event Status	38	Read Only - see Subsection 6.8

Parameter	No.	Notes
PROGRAMMER DATA (Continued)		
Segment Time Remaining	39	Read Only
Programmer Commands	40	Write Only - value range 0001 - 0013 (see Subsection 6.4)
Delayed Start Time	41	
Power Fail Recovery	42	Cold Start or Warm Start - see Subsection 6.9
External Selection Control	43	
Hold Time Value	44	Read Only
Program Index (used for Read/Write)	45	Used with registers 1001 to 1058
Manufacturer ID	121	Read Only - 231 (representing "W1")
Equipment ID	122	Read Only - number 4400
SEGMENT DATA		
Number of Cycles Programmed	1001	
Number of Cycles Completed	1002	Read Only
Preset x60 Mode	1003	
Auto-Hold Type	1004	0 = OFF, 1 = above SP, 2 = below SP, 3 = both
Hold On	1005	0 = Ramps & Dwells, 1 = Dwells only, 2 = Ramps only
Hold Band value	1006	
Final Setpoint Value (Segment 1)	1007	
Final Setpoint Value (Segment 2)	1008	
Final Setpoint Value (Segment 3)	1009	
Final Setpoint Value (Segment 4)	1010	
Final Setpoint Value (Segment 5)	1011	
Final Setpoint Value (Segment 6)	1012	
Final Setpoint Value (Segment 7)	1013	
Final Setpoint Value (Segment 8)	1014	
Final Setpoint Value (Segment 9)	1015	
Final Setpoint Value (Segment 10)	1016	
Final Setpoint Value (Segment 11)	1017	
Final Setpoint Value (Segment 12)	1018	
Final Setpoint Value (Segment 13)	1019	
Final Setpoint Value (Segment 14)	1020	
Final Setpoint Value (Segment 15)	1021	
Final Setpoint Value (Segment 16)	1022	
Time/Rate Value (Segment 1)	1023	Time Mode: Value in minutes (x60 = OFF) or seconds (x60 = ON) Rate Mode: Value in LSD/hour (x 60 = OFF) or LSD/minute (x 60 = ON)
Time/Rate Value (Segment 2)	1024	
Time/Rate Value (Segment 3)	1025	
Time/Rate Value (Segment 4)	1026	
Time/Rate Value (Segment 5)	1027	
Time/Rate Value (Segment 6)	1028	
Time/Rate Value (Segment 7)	1029	

Parameter	No.	Notes
SEGMENT DATA (Continued)		
Time/Rate Value (Segment 8)	1030	Time Mode: Value in minutes (x60 = OFF) or seconds (x60 = ON) Rate Mode: Value in LSD/hour (x 60 = OFF) or LSD/minute (x 60 = ON)
Time/Rate Value (Segment 9)	1031	
Time/Rate Value (Segment 10)	1032	
Time/Rate Value (Segment 11)	1033	
Time/Rate Value (Segment 12)	1034	
Time/Rate Value (Segment 13)	1035	
Time/Rate Value (Segment 14)	1036	
Time/Rate Value (Segment 15)	1037	
Time/Rate Value (Segment 16)	1038	
Event Outputs (1,2,3,4) - Segment 1	1039	
Event Outputs (1,2,3,4) - Segment 2	1040	
Event Outputs (1,2,3,4) - Segment 3	1041	
Event Outputs (1,2,3,4) - Segment 4	1042	
Event Outputs (1,2,3,4) - Segment 5	1043	
Event Outputs (1,2,3,4) - Segment 6	1044	
Event Outputs (1,2,3,4) - Segment 7	1045	
Event Outputs (1,2,3,4) - Segment 8	1046	
Event Outputs (1,2,3,4) - Segment 9	1047	
Event Outputs (1,2,3,4) - Segment 10	1048	
Event Outputs (1,2,3,4) - Segment 11	1049	
Event Outputs (1,2,3,4) - Segment 12	1050	
Event Outputs (1,2,3,4) - Segment 13	1051	
Event Outputs (1,2,3,4) - Segment 14	1052	
Event Outputs (1,2,3,4) - Segment 15	1053	
Event Outputs (1,2,3,4) - Segment 16	1054	
Tag Name (1st/2nd characters)	1055	
Tag Name (3rd/4th characters)	1056	
Tag Name (5th/6th characters)	1057	
Tag Name (7th/8th characters)	1058	
Program 1 Parameters (as above)	1101 - 1158	
Program 2 Parameters (as above)	1201 - 1258	
Program 3 Parameters (as above)	1301 - 1358	
Program 4 Parameters (as above)	1401 - 1458	
Program 5 Parameters (as above)	1501 - 1558	
Program 6 Parameters (as above)	1601 - 1658	
Program 7 Parameters (as above)	1701 - 1758	
Program 8 Parameters (as above)	1801 - 1858	

6.4 PROGRAMMER COMMANDS

Word Parameter 40

This Write Only word parameter is used to convey commands to be implemented by the Setpoint Programmer. Four digits are used to specify the command to be executed:

Value	Command	Value	Command
0001	Run currently-selected program ^{1,2}	0011	Disable x60 Mode
0002	Manually hold currently-running program ¹	0012	Enable Program Lock
0003	Release Manual Hold ¹	0013	Diabie Program Lock
0004	Jump forward one segment ²	0021	Run Program 1 ^{1,2,3}
0005	Abort currently-running program ¹	0022	Run Program 2 ^{1,2,3}
0006	Start on Controller Setpoint	0023	Run Program 3 ^{1,2,3}
0007	Start on Process Variable	0024	Run Program 4 ^{1,2,3}
0008	End on Controller Setpoint	0025	Run Program 5 ^{1,2,3}
0009	End on Final Value	0026	Run Program 6 ^{1,2,3}
0010	Enable x60 Mode	0027	Run Program 7 ^{1,2,3}
		0028	Run Program 8 ^{1,2,3}

1. If External Run/Hold/Abort Control is active, an Exception Response (see Subsection 6.3.2) is returned.
2. If program is in Manual Hold, an Exception Response (see Subsection 6.3.2) is returned.
3. If External Program Selection is active, an Exception Response (see Subsection 6.3.2) is returned.

6.5 PROGRAMMER STATUS 1

Word Parameter 33

This word parameter obtains status information from the Setpoint Programmer in the form of a five-digit decimal number which, when converted into binary form, indicates status as follows:

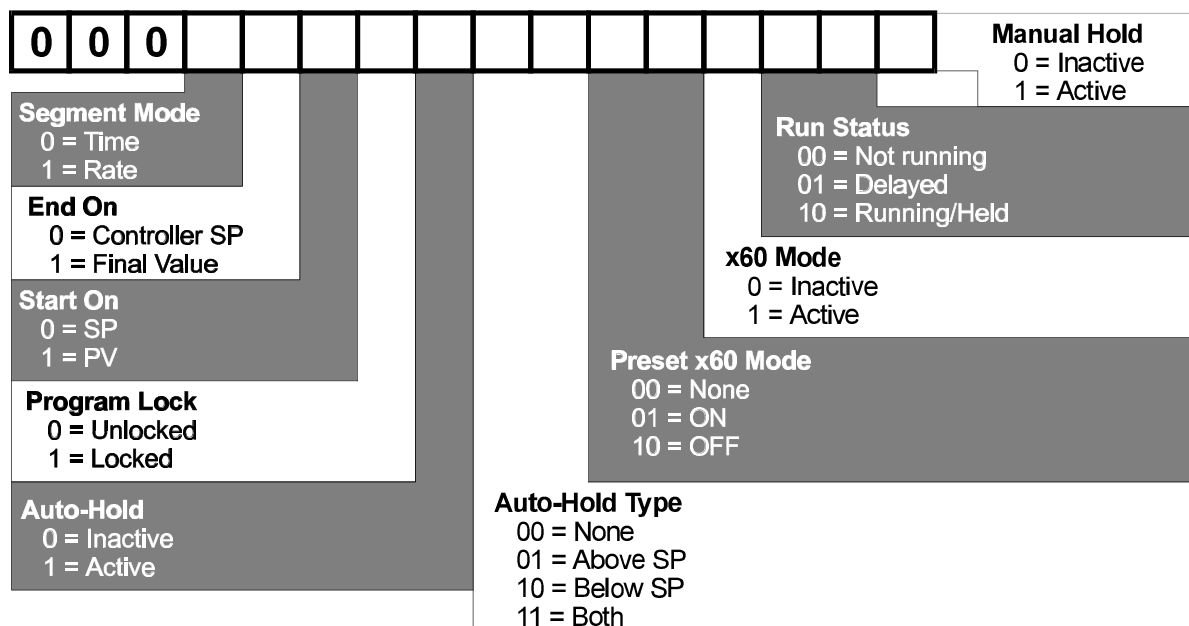

6.6 SEGMENT MODE

Word Parameter 32

This parameter controls the overall programming algorithm of the instrument; Time Mode or Rate Mode. Changing this parameter will cause all other Program Definitions to be set to default values, which takes in excess of one second to complete. Software which writes to this parameter must therefore take this time into account before expecting a reply.

6.7 PROGRAMMER STATUS 2

Word Parameter 34

This Read Only word parameter gives a bit map representing the current status of the Event Output and Program Control Input ports. When it is interrogated, the response is in a five-digit format which contains a decimal representation of an eight-bit binary number whose bits have the following significance:

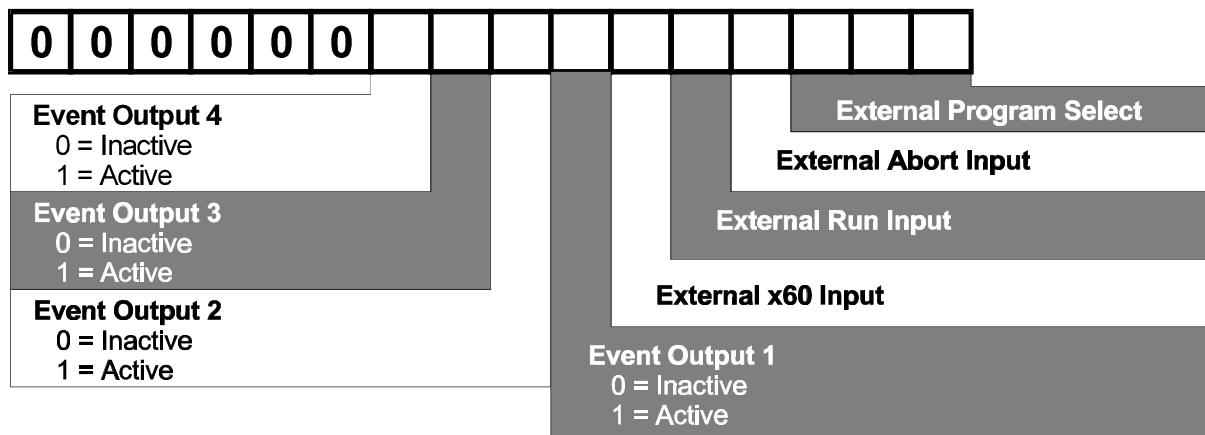

6.8 CURRENT SEGMENT EVENT STATUS

Word Parameter 38

This read only word parameter returns the status of the four event outputs for the currently-executed segment (as defined by Current Segment Number and Current Program Number). It has six digits; the first two are 04 and each of the remaining digits (Event 1 being represented by the left-most digit etc.) may be 1 (active) or 0 (inactive).

6.9 POWER FAIL RECOVERY

Word Parameter 42

This word parameter defines the mode of recovery on restoration of power after a power failure.

If Real Time Clock is not fitted: The decimal point position digit will be set to 0 and the remaining four digits will be set to either 0000 (Execute Cold Start - entry into Base Mode with Program Number set as when power failed and Segment Number blank) or 0001 (Execute Warm Start - program resumed from point when power failed). Any attempt to set these digits to a value outside this range will cause an exception response to be returned.

If Real Time Clock is fitted: The decimal point position digit will be set to 0 and the remaining four digits will be set to either 0000 (Execute Cold Start - entry into Base Mode with Program Number set as when power failed and Segment Number blank) or in the form *hhmm* (*hh* = hours, *mm* = minutes) in the range 0001 to 4800 (Execute Warm Start if power is restored within time specified, otherwise execute Cold Start). Any attempt to set these digits to a value outside this range will cause an exception response to be returned.

APPENDIX A

PRODUCT SPECIFICATION

UNIVERSAL INPUT

General

Maximum per Controller:	One
Input Sample Rate:	Four samples/second
Digital Input Filter:	Time constant selectable from front panel - 0.0 (i.e. OFF), 0.5 to 100.0 seconds in 0.5-second increments.
Input Resolution:	14 bits approximately; always four times better than display resolution.
Input Impedance:	Greater than 100M Ω resistive (except for DC mA and V inputs).
Isolation:	Universal input isolated from all outputs except SSR at 240V AC.
Process Variable Offset:	Adjustable \pm input span.

Thermocouple

Ranges selectable from front panel:

Type	Input Range	Displayed Code	Type	Input Range	Displayed Code
R	0 - 1650°C	1127	K	-200 - 760°C	6726
R	32 - 3002°F	1128	K	-328 - 1399°F	6727
S	0 - 1649°C	1227	K	-200 - 1373°C	6709
S	32 - 3000°F	1228	K	-328 - 2503°F	6710
J	0.0 - 205.4°C	1415	L	0.0 - 205.7°C	1815
J	32.0 - 401.7°F	1416	L	32.0 - 402.2°F	1816
J	0 - 450°C	1417	L	0 - 450°C	1817
J	32 - 842°F	1418	L	32 - 841°F	1818
J	0 - 761°C*	1419	L	0 - 762°C	1819
J	32 - 1401°F	1420	L	32 - 1403°F	1820
T	-200 - 262°C	1525	B	211 - 3315°F	1934
T	-328 - 503°F	1526	B	100 - 1824°C	1938
T	0.0 - 260.6°C	1541	N	0 - 1399°C	5371
T	32.0 - 501.0°F	1542	N	32 - 2550°F	5324

* Default setting

Calibration: Complies with BS4937, NBS125 and IEC584.

Sensor Break Protection: Break detected within two seconds. Control outputs set to OFF (0% power); Alarms operate as if the process variable has gone over-range.

Resistance Temperature Detector (RTD) and DC mV

Ranges selectable from front panel:

Input Range	Displayed Code	Input Range	Displayed Code	Input Range	Displayed Code
0 - 800°C*	7220	-149.7 - 211.9°F	2231	-200 - 206°C	2297
32 - 1472°F	7221	0 - 300°C	2251	-328 - 402°F	2298
32 - 571°F	2229	0.0 - 100.9°C	2295	-100.9 - 537.3°C	7222
-100.9 - 100.0°C	2230	32.0 - 213.6°F	2296	-149.7 - 999.1°F	7223

* Default setting

Type and Connection: Three-wire Pt100

Calibration: Complies with BS1904 and DIN43760.

Lead Compensation: Automatic scheme.

RTD Sensor Current: 150 μ A (approximately)

Sensor Break Protection: Break detected within two seconds. Control outputs set to OFF (0% power); Alarms operate as if the process variable has gone under-range.

DC Linear

Ranges Selectable from Front Panel:

Input Range	Displayed Code	Input Range	Displayed Code
0 - 20mA	3413	0 - 5V	4445
4 - 20mA*	3414	1 - 5V	4434
0 - 50mV	4443	0 - 10V*	4446
10 - 50mV	4499	2 - 10V	4450

* Default setting

Scale Range Maximum: -1999 to 9999. Decimal point as required.

Scale Range Minimum: -1999 to 9999. Decimal point as for Scale Range Maximum.

Minimum Span:	1 display LSD.
Sensor Break Protection:	Applicable to 4 - 20mA, 1 - 5V and 2 - 10V ranges only. Break detected within two seconds. Control outputs set to OFF (0% power); Alarms operate as if the process variable has gone under-range.

OUTPUT 1

General

Types Available:	Relay (as standard), SSR Drive and DC as options.
------------------	---

Relay

Contact Type:	Single pole double throw (SPDT).
Rating:	2A resistive at 120/240V AC.
Lifetime:	>500,000 operations at rated voltage/current.
Isolation:	Inherent.

SSR Drive/TTL

Drive Capability:	SSR >4.3V DC into 250 Ω minimum.
Isolation:	Not isolated from input or other SSR outputs.

DC

Resolution:	Eight bits in 250mS (10 bits in 1 second typical, >10 bits in >1 second typical).
Update Rate:	Every control algorithm execution.
Ranges:	0 - 20mA, 4 - 20mA, 0 - 10V, 0 - 5V
Load Impedance:	0 - 20mA: 500 Ω maximum 4 - 20mA: 500 Ω maximum 0 - 10V: 500 Ω minimum 0 - 5V: 500 Ω minimum
Isolation:	Isolated from all other inputs and outputs.
Range Selection Method:	Link jumper or DIP switch and front panel code.

OUTPUT 2**General**

Types Available: Relay, SSR Drive and DC.

Relay

Contact Type: Single pole double throw (SPDT).

Rating: 2A resistive at 120/240V AC.

Lifetime: >500,000 operations at rated voltage/current.

Isolation: Inherent.

SSR Drive/TTL

Drive Capability: SSR >4.3V DC into 250 Ω minimum.

Isolation: Not isolated from input or other SSR outputs.

DC

Resolution: Eight bits in 250mS (10 bits in 1 second typical, >10 bits in >1 second typical).

Update Rate: Every control algorithm execution.

Ranges: 0 - 20mA, 4 - 20mA, 0 - 10V, 0 - 5V

Load Impedance: 0 - 20mA: 500 Ω maximum
4 - 20mA: 500 Ω maximum
0 - 10V: 500 Ω minimum
0 - 5V: 500 Ω minimum

Isolation: Isolated from all other inputs and outputs.

Range Selection Method: Link jumper or DIP switch and front panel code.

OUTPUT 3**General**

Types Available: Relay, DC linear (Recorder Output only)

Relay

Contact Type:	Single pole double throw (SPDT).
Rating:	2A resistive at 120/240V AC.
Lifetime:	> 500,000 operations at rated voltage/current.
Isolation:	Inherent.

SSR Drive/TTL

Drive Capability:	SSR > 4.3V DC into 250 Ω minimum.
Isolation:	Not isolated from input or other SSR outputs.

DC

Resolution:	Eight bits in 250mS (10 bits in 1 second typical, > 10 bits in > 1 second typical).
Update Rate:	Every control algorithm execution.
Ranges:	0 - 20mA, 4 - 20mA, 0 - 10V, 0 - 5V
Load Impedance:	0 - 20mA: 500 Ω maximum 4 - 20mA: 500 Ω maximum 0 - 10V: 500 Ω minimum 0 - 5V: 500 Ω minimum
Isolation:	Isolated from all other inputs and outputs.
Range Selection Method:	Link jumper or DIP.

LOOP CONTROL

Automatic Tuning Types:	Pre-Tune and Self-Tune.
Proportional Bands:	0 (OFF), 0.5% - 999.9% of input span at 0.1% increments.
Reset (Integral Time Constant):	1s - 99min 59s and OFF
Rate (Derivative Time Constant):	0 (OFF) - 99 min 59 s.
Manual Reset (Bias):	Added each control algorithm execution. Adjustable in the range 0 - 100% of output

	power (single output) or –100% to +100% of output power (dual output).
Deadband/Overlap:	–20% to +20% of Proportional Band 1 + Proportional Band 2.
ON/OFF Differential:	0.1% to 10.0% of input span.
Auto/Manual Control:	User-selectable with “bumpless” transfer into and out of Manual Control.
Cycle Times:	Selectable from 0.5secs to 512 secs in binary steps.
Setpoint Range:	Limited by Setpoint Maximum and Setpoint Minimum.
Setpoint Maximum:	Limited by Setpoint and Range Maximum.
Setpoint Minimum:	Limited by Range Minimum and Setpoint.
Setpoint Ramp:	Ramp rate selectable 1 - 9999 LSDs per hour and infinite. Number displayed is decimal-point-aligned with selected range.

ALARM CONTROL

Maximum Number of Alarms:	Two “soft” alarms plus Loop Alarm
Max. No. of Outputs Available:	Up to two outputs can be utilised for alarm purposes.
Combinatorial Alarms:	Logical OR or AND of alarms to an individual hardware output is available.

PROGRAM FACILITIES

Programs (profiles):	Eight, each with free-form segments
Length of Program:	Adjustable in the range 1 to 16 segments; programs cascadable - maximum length 121 segments
Segment Types:	Ramp, Dwell, Join, Repeat or End
Program Cycling:	Range 1 to 9999, infinite

Delayed Start:	May be set in the range 0 to 99:59 (hours:minutes). One setting applies to all programs
Control:	Run, Hold, Abort, x60 (local or remote) Select Program (local or remote) Jump to next segment.
Start From:	Either current process variable value or controller setpoint value
End On:	Final Value or controller setpoint
Auto-Hold:	Off, below setpoint only, above setpoint only or above and below setpoint. On ramps only, on dwells only or on both ramps and dwells. Auto-Hold band may be set from 0 to input span.
Timebase:	Either hours:minutes or minutes:seconds (x60); x60 pre-programmable or may be set during Program Run.
Segment Time:	May be set in the range 0 to 99:59 (hours:minutes or minutes:seconds)
Ramp Rate:	0 to 9999 least significant digits per hour or minute

END OF PROGRAM OUTPUT

Type:	Relay
Contact Type:	Single pole, double throw (SPDT Form C)
Rating:	5A resistive @ 120/240V AC
Lifetime:	> 100,000 operations @ rated voltage/current
Isolation:	Inherent

EVENT OUTPUTS - OPTION

Type:	Relay (4)
Contact Type:	Single pole, single throw; normally open.
Rating:	5A resistive @ 120/240V AC

Lifetime:	> 100,000 operations @ rated voltage/current
Isolation:	Inherent
Programmability:	Each event is programmable to either OFF or ON for each segment.

DIGITAL (REMOTE PROGRAM CONTROL) INPUTS - OPTION

Type:	Voltage-free contact and TTL-compatible
Number available:	Six: (a) Run/Hold, x60, Abort (b) Three (binary-coded) Program Select
Active State:	Max. Contact Resistance (Closed) = 50Ω Max. Voltage (TTL) for "0" = 0.8V Min. Voltage for "0" = -0.6V
Non-Active State:	Min. Contact Resistance (Open) = $5,000\Omega$ Min. Voltage (TTL) for "1" = 2.0V Max. Voltage for "1" = 24.0V
Max. Input Delay (OFF - ON):	0.25 seconds
Min. Input Delay (ON - OFF):	0.25 seconds

RS485 SERIAL COMMUNICATIONS (OPTION)

System: Multi-drop, half duplex. May operate in Slave Mode (slave address 1 - 32) or Master Mode (transmitting current setpoint value to up to 32 Controllers). Transmitting device drives lines to appropriate levels; the outputs on each non-transmitting device are set to a high impedance in order that other devices may transmit.

NOTE: All instruments in this range having an RS485 serial communications facility conform to the following standard:

1. Each transmitter must release the transmission lines within 6ms of the last character in a message; delays due to buffers such as those in UARTs within the master device must be taken into account.
2. A transmitter must not start transmission until 6ms has elapsed since reception of the last character of a message.

To avoid line contention problems, ensure that all devices connected to the communications port follow the same standard.

Data Format: Even parity, seven data bits and one stop bit.

Baud Rate: Selectable: 1200, 2400, 4800 (default) or 9600 Baud.

PERFORMANCE

Reference Conditions

Generally as BS5558.

Ambient Temperature: $20^{\circ}\text{C} \pm 2^{\circ}\text{C}$

Relative Humidity: 60 - 70%

Supply Voltage: 90 - 264V AC 50Hz $\pm 1\%$

Source Resistance: $< 10\Omega$ for thermocouple input

Lead Resistance: $< 0.1\Omega/\text{lead}$ balanced (Pt100)

Performance Under Reference Conditions

Common Mode Rejection: $> 120\text{dB}$ at 50/60Hz giving negligible effect at up to 264V 50/60Hz.

Series Mode Rejection: $> 500\%$ of span (at 50/60Hz) causes negligible effect.

DC Linear Inputs

Measurement Accuracy: $\pm 0.25\%$ of span $\pm 1\text{LSD}$.

Thermocouple Inputs

Measurement Accuracy: $\pm 0.25\%$ of span $\pm 1\text{LSD}$. NOTE: Reduced performance with Type "B" Thermocouple between 100 - 600°C (212 - 1112°F).

Linearisation Accuracy: Better than $\pm 0.2^{\circ}\text{C}$ any point, any 0.1°C range ($\pm 0.05^{\circ}\text{C}$ typical). Better than $\pm 0.5^{\circ}\text{C}$ any point, any 1°C range.

Cold Junction Compensation: Better than $\pm 0.7^{\circ}\text{C}$.

RTD Inputs

Measurement Accuracy:	$\pm 0.25\%$ of span ± 1 LSD
Linearisation Accuracy:	Better than $\pm 0.2^\circ\text{C}$ any point, any 0.1°C range ($\pm 0.05^\circ\text{C}$ typical). Better than $\pm 0.5^\circ\text{C}$ any point, any 1°C range.

DC Outputs - Accuracy

Output 1:	$\pm 0.5\%$ (mA @ 250Ω , V @ $2k\Omega$); 2% underdrive (4 - 20mA) and overdrive applies.
Output 2:	$\pm 0.5\%$ (mA @ 250Ω , V @ $2k\Omega$); 2% underdrive (4 - 20mA) and overdrive applies.
Output 3 (Recorder Output):	$\pm 0.25\%$ (mA @ 250Ω , V @ $2k\Omega$); Degrades linearly to $\pm 0.5\%$ for increasing burden (to specification limits).

Operating Conditions

Ambient Temperature (Operating):	0°C to 55°C
Ambient Temperature (Storage):	-20°C to 80°C
Relative Humidity:	20% - 95% non-condensing
Supply Voltage:	90 - 264V AC 50/60Hz (standard) 20 - 50V AC 50/60Hz or 22 - 65V DC (option)
Source Resistance:	1000Ω maximum (thermocouple)
Lead Resistance:	50Ω per lead maximum balanced (Pt100)

Performance Under Operating Conditions

Temperature Stability:	0.01% of span/ $^\circ\text{C}$ change in ambient temperature.
Cold Junction Compensation (thermocouple Only):	Better than $\pm 1^\circ\text{C}$.

Supply Voltage Influence:	Negligible.
Relative Humidity Influence:	Negligible
Sensor Resistance Influence:	Thermocouple 100 Ω : <0.1% of span error Thermocouple 1000 Ω : <0.5% of span error RTD Pt100 50 Ω /lead: <0.5% of span error
Radiated RF Field Influence:	Degradation of Output 1 accuracy to 3% at spot frequencies in the range 80 - 350MHz at field strength of 10V/m.

ENVIRONMENTAL

Operating Conditions:	See PERFORMANCE .
EMI Susceptibility:	Designed to meet EN50082-1:1992 and EN50082-2:1995.
EMI Emissions:	Designed to meet EN50081-1:1992 and EN50081-2:1994.
Safety Considerations:	Designed to comply with EN 61010-1:1993.
Supply Voltage:	90 - 264V AC 50/60Hz (standard) 20 - 50V AC 50/60Hz or 22 - 65V DC (option)
Power Consumption:	4 watts approximately.
Front Panel Sealing:	To IP65.

PHYSICAL

Dimensions:	Depth - 100mm approximately Front Panel: Width - 96mm, Height - 96mm (¼-DIN)
Mounting:	Plug-in with panel mounting fixing strap. Panel cut-out 92mm x 92mm.
Terminals:	Screw type (combination head).
Weight:	0.21kg maximum

ALPHABETIC INDEX

A

AC/DC (24V) Supply	
Connections	2-5
Voltage range	2-5
Alarm Inhibit Facility	
Description of	4-7

B

Baud Rate	
MODBUS protocol	6-1
Broadcast Messages	
MODBUS RTU protocol	6-2

C

Character Transmission	
MODBUS RTU protocol	6-1
Communications	
MODBUS bit parameters	6-7
MODBUS word parameters	6-7
Communications Data Format	
MODBUS RTU protocol	6-1
Communications Message Format	5-1
Configuration Mode	
Automatic exit from	4-7
Entry into	4-1
Exit from	4-7
Controller Dimensions	A-11
Cyclic Redundancy Checksum	
Description of	6-2
Cyclic Redundancy Checksum (CRC)	
Description of	6-2

D

Data Padding	6-4
Digital Input Option PCB	
Installation/removal	3-4

E

End of Message Character	5-2
Error Responses	
MODBUS RTU protocol	6-6
Event Output Option PCB	
Installation/removal	3-5
Exception Responses	
MODBUS RTU protocol	6-6

F

Front Panel	
Dimensions	2-1
Projection from mounting panel	2-1
Function Number	
MODBUS RTU message format	6-2
Fuse Rating	
AC/DC (24V) supply	2-5
Mains (line) supply	2-5

H

Hardware Definition Codes	4-1
---------------------------	-----

I

Input Type Selection	3-6
----------------------	-----

J

JBUS Function Names	6-2
---------------------	-----

L

Line (Mains) Supply	
Connections	2-5
Power consumption	2-5
Voltage range	2-5
Line Turn-Round	
MODBUS RTU protocol	6-1

M

Main Dimensions	2-1
Mains (Line) Supply	
Connections	2-5
Power consumption	2-5
Voltage range	2-5
Message Formats	
MODBUS RTU protocol	6-2
Message Types	5-2
MODBUS Functions Supported	6-2
MODBUS RTU Protocol	6-1
Multi-Word Write Function	
MODBUS protocol	6-1

O

Output 1 Type Selection	3-7
Output 2 Option PCB	
Removal/replacement	3-3
Output 2 Type Selection	3-8
Output 3 Option PCB	
Removal/replacement	3-3
Output 3 Type Selection	3-8
Output Relay Contact Rating	
End of Program and Event outputs	2-8
Outputs 1, 2 and 3	2-8

P

Panel-Mounting	
Cut-out dimensions (multiple installation)	2-1
Cut-out dimensions (single installation)	2-1
Maximum panel thickness	2-1
Setpoint Programmer dimensions	2-1
Panel-Mounting Procedure	2-2
Parity	
MODBUS RTU protocol	6-1

R

RS485 Communications	6-1
RS485 Loading Limits	6-6
RS485 Serial Communications Option PCB	
Removal/replacement	3-3
RTU Form	
MODBUS protocol	6-2

S

Scan Tables Command	5-4
Sensor Break	
Effect on outputs (DC linear inputs)	A-3
Effect on outputs (RTD inputs)	A-2
Effect on outputs (thermocouple inputs)	A-2
Serial Communications	6-1
Setpoint Programmer Address	
MODBUS RTU message format	6-2
Setpoint Programmer Status	
MODBUS RTU protocol	6-4
Start of Message Character	5-1 - 5-2

T

Two-wire Communications 6-1

V

VMD Outputs
Safety interlock 2-8

W

Write Operations
MODBUS RTU protocol 6-1