

SSR P Series Installation/Operations

1. Mount the unit so the line and load connections are at the top and upward airflow over the heat sink fins is unrestricted.
2. Connect the load to the proper terminals (refer to the input/output connections diagram) using appropriately sized and insulated conductors. (All input/output conductors should be stranded copper wire only. Minimum temperature rating is 75° C.

WARNING

Hazardous voltages exist at the exposed SSR P series (LINE and LOAD) terminals unless the fuse disconnect or circuit breaker that supplies power to the unit is open or off. This is true even when the gating control method used has the semiconductors turned off.

3. Connect input lines from the fused disconnect or circuit breaker to the proper terminals (refer to the input/output connections diagram) using appropriately sized and insulated conductors. (NOTE: Input power should be routed through a fused disconnect or circuit breaker with a fuse or trip rating of 100% to 125% of the current rating stamped on the nameplate of the SSR P series unit.) An optional I²T fuse kit is available (FK2). This is required to protect the SSR if the load shorts.

WARNING

Required branch circuit overcurrent protection is to be provided in accordance with the national and local codes of the inspecting authority.

4. Connect optional current line or overcurrent trip. Run L1 through current transformer one time. Connect optional plus into trigger and adjust pot to desired current or trip level.

5. Energize unit. With temperature controller OFF, adjust BIAS control for zero output. Next, set temperature controller demand for 100% output and adjust GAIN control for full output. The LED may be used for adjustment purposes. (NOTE: When LED is brightly illuminated, the output is at 100%.) Adjust current limit or overcurrent trip potentiometer to desired level when these options are used.

6. Circuit card P/N H0022988 has been replaced with a new phase angle control card P/N 260009.00. This new card is of surface mount construction, is forward and backward compatible, and is UL & CSA certified. (NOTE: Requires a jewelers screw driver for multi-turn bias & gain adjustments.) The 24-vac burden in 2.5va and is not sensitive to line voltage changes. The input will accept the standard 4-20mADC signal @250ohm impedance or 500-ohm and is switch selectable. The control card has a 6-position selector switch. SW1 POS 1 and POS 2 are each a 500-ohm resistor. Close SW1 POS 1 or SW1 POS 2 and the input is 500-ohms. Close SW1 POS 1 and SW1 POS 2 and the input is 250-ohms. SW1 POS 1 and POS 2 open input impedance is 20kΩ impedance for manual potentiometer or 0-10 Vdc control.

Ramp Speed Adjustment:

- Close SW1 POS 3 ramp is 4.5 seconds
- Close SW1 POS 4 ramp is 3.5 seconds
- Close SW1 POS 5 ramp is 2.5 seconds
- Close SW1 POS 6 ramp is 1.5 seconds
- Leave SW1 POS 3 through SW1 POS 6 open ramp is 0.5 seconds
- Leave SW1 POS 3 through SW1 POS 6 closed ramp is approximately 13 seconds.

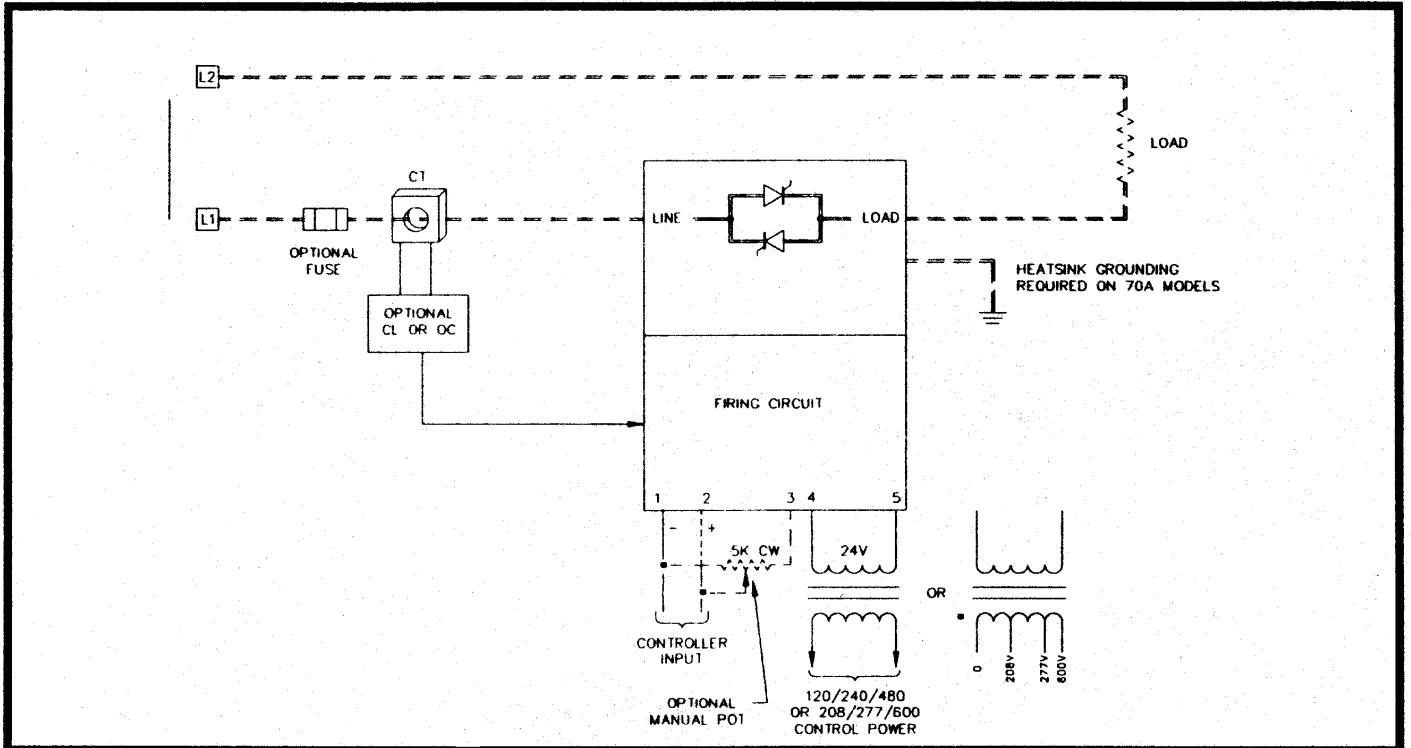

Typical Input/Output Connections for the 50P and the 100P

ISE, Inc. - 10100 Royalton Rd. Cleveland, OH 44133 - Tel: (440) 237-3200 - Fax: (440) 237-1744
<http://iseinc.com>