

Microprocessor-Based SCR Power Controller Designed for Application Flexibility

For over thirty years Watlow has been manufacturing solid state power controllers. Watlow's Power Series represents the latest in SCR power controller technology. This microprocessor-based product offers features and application flexibility unmatched by any other SCR power controller on the market today.

Capabilities include single-phase and three-phase models from 65 to 250 amps. Field configurable phase angle or zero cross firing improves application flexibility on site where you need it. 50/60Hz independent operation means you can operate almost everywhere in the world without special calibration considerations. Serial communications utilizing Modbus™ protocol allows for remote control setup, and monitoring of load status from a nearby computer station or control room.

On-board semiconductor fusing improves reliability by protecting the SCRs from heater short circuits. Plus, on-board heater bakeout and control diagnostics can help eliminate initial start up problems. All this in a touch-safe package that can be quickly and easily mounted in your control cabinet.

Agency approvals ensure product that meets world safety and operational standards. You can be assured your power controller will be ideal wherever you choose to do business.

UL® is a registered trademark of the Underwriter's Laboratories
Modbus™ is a trademark of AEG Schneider Automation



Features and Benefits

Microprocessor-based technology

- Extremely versatile, field configurable

Snap-fit on a pre-mounted plate

- Easy installation

Models 65 through 250 amp ratings

- Handles a wide range of loads

Adjustable soft start

- Application flexibility

Heater and control diagnostics capabilities

- Monitor actual heater and control performance

Electrically touch-safe package

- Increased safety for installer and users

Serial communications with Modbus™ RTU protocol

- Computer control and/or monitoring

Multizone capability

- Increased application flexibility, reduced panel space



WIN-PS-20

Watlow Controls

A subsidiary of Watlow, Designer and Manufacturer of Industrial Heaters, Sensors and Controls

1241 Bundy Boulevard
Winona, Minnesota 55987-5580 USA

ISO 9001



Specifications—1875

Power Bases

- Single-phase, (2 SCRs)
- 3-phase, 2 leg control, (4 SCRs)
Resistive load only, zero cross firing only
- 3-phase, 3 leg control, (6 SCRs)
- 3-phase, 3 leg control, (6 SCRs) for 4 wire wye loads
- Multizone, two and three single-phase zones

Output Control Options

- Zero cross contactor, V_{rms} (dc) input
- Zero cross control, fixed time base
 - Time base 1 or 4 seconds with digital programmer
- Zero cross control, variable time base
- Phase angle control and phase angle control with current limit (not for 3-phase, 2 leg models)
 - Soft start factory default 4 seconds upon power-up, and adjustable from 0.0 to 120 seconds
 - Soft start upon input signal change, output rate of change adjustable to limit max rate of change from 0.1 to 100% per 0.1 second. Factory default 10%.
- Current transformer included when required
- Line voltage compensated (variable time base and phase angle controllers only)
- Standby or non-operational mode

Output Voltage and Current Rating

- 24V~ to 120V~ (+10%, -15%)
- 200V~ to 480V~ (+10%, -15%)
- 200V~ to 600V~ (+10%, -15%)
- 65 through 250 amps per pole, model dependent; see Output Amperage Chart and Rating Curves
- Minimum load 1 amp rms ac
- Maximum leakage current 5mA

Alarms

- Single alarm relay
- Latching or non-latching
- Separate high and low values
- Alarm silencing (inhibit) on power up for alarm
- Alarm indication LEDs, shorted SCR, open heater, fuse
- Electromechanical relay, form C contact, software configurable
 - Minimum load current 10mA @ 5V $_{\text{rms}}$ (dc)
 - Rated resistive loads: 3 amps @ 250V~ or 30V $_{\text{rms}}$ (dc) max., inductive load rating 1.5 amps with a power factor ≥ 0.4 without contact suppression

Heater Bakeout

- For single-phase (phase to neutral) and 3-phase 6 SCR models only (not for 3-phase, 2 leg models)
- Soft start with over current trip, runs until programmed bakeout time expires, then goes burst or phase angle firing. Factory default of 24 hours.
- Adjustable 0 - 9999 minutes with over current trip
- Internal current transformer included

Command Signal Input

Analog

- DC contactor 3.5 to 30V $_{\text{rms}}$ (dc), must turn off at 2.5V $_{\text{rms}}$ (dc)
- Field selectable linear voltage and current of low and high points within 0-20mA and 0-10V $_{\text{rms}}$ (dc)
- Manual control input through front panel
- Factory default 4-20mA input
- Voltage input impedance 11k Ω nominal
- Current input impedance 100 Ω nominal

Digital

- On-board digital programmer/display and optional serial communications

Retransmit

- Field selectable and scaleable within 0-20mA, 800 Ω maximum or 0-10V $_{\text{rms}}$ (dc), load, 1K Ω minimum load. The default is 4-20mA.

- Resolution:
 - mA ranges = $\pm 2\mu\text{A}$
 - V $_{\text{rms}}$ (dc) = ranges 2.5V nominal
- Calibration accuracy:
 - mA ranges = $\pm 5\mu\text{A}$
 - V $_{\text{rms}}$ (dc) ranges = 10V nominal
- Temperature Stability: 100ppm $^{\circ}\text{C}$

Digital Programmer/Display and Communications Capabilities

- Programming functions
 - Adjust input and output control type, alarms and soft start. Heater bakeout and current limit prompts also.
- Monitoring functions
 - Display input and output values along with actual output current
- Data retention of digital programmer/display upon power failure via nonvolatile memory

Serial Communications

- RS-232 for single drop control
- EIA-485 for single or multidrop control
 - 32 units maximum can be connected. With additional 485 repeater hardware, up to 247 units may be connected
- Isolated
- Modbus™ RTU protocol
- 1200, 2400, 4800, 9600, 19200 baud rates

Controller Power Supply

- Universal line voltage input range 100 to 240V~ (+10%, -15%) at 55VA max
- 50/60Hz $\pm 5\%$ line frequency independent
- Controller line voltage for electronic power supply can be run on separate line voltage

Natural Convection and Fan Cooled Models

- Cabinet venting may be required
- See chart on the back page for models that include fan cooling

Power Dissipation (Watts)

- Approximately 1.25 watts/amp per controlled leg

Isolation

- Command signal to load and line/load to ground 2200V~ minimum
- On-board semiconductor fuses provide SCR protection

Mounting

- Mounts on a removable sub-plate
- Heat sink fins must be mounted in vertical orientation

High Current Terminals

- Touch safe
- $\frac{3}{8}$ inch Allen head compression terminals will accept #6 AWG to 350 MCM wire. Allen wrench adapter (included) for $\frac{3}{8}$ inch socket, or 10 mm, 6 point only.
- Torque to 180 in.-lbs. (20.3 Nm.)
- Wire strip to 30 mm (1 $\frac{1}{8}$ inch)

Controller Terminals

- Touch safe
- 2.5 mm ($\frac{1}{8}$ inch) blade screwdriver, accepts 12-22 AWG or 2 No. 22-18 AWG wires.
- Torque to 8 in.-lbs. (0.9 Nm.)
- Wire strip to 6 mm (0.24 inch)

Operating Environment

- 50 $^{\circ}\text{C}$ (122 $^{\circ}\text{F}$) base rating
 - 0 to 60 $^{\circ}\text{C}$ (32 to 140 $^{\circ}\text{F}$) fan cooled
 - 0 to 65 $^{\circ}\text{C}$ (32 to 149 $^{\circ}\text{F}$) natural convection cooled
- 0 to 90% RH, non-condensing
- Meets EN50178, Pollution degree 3

Storage Temperature

- -40 to 85 $^{\circ}\text{C}$ (-40 to 185 $^{\circ}\text{F}$)

Shipping Weight

- 10.3 kg. (23 lbs.)

Agency Approvals

- UL® 508 and C-UL listed, file #E73741
- Applied for EN50178

Package Style C Dimensions

Power Series Front View

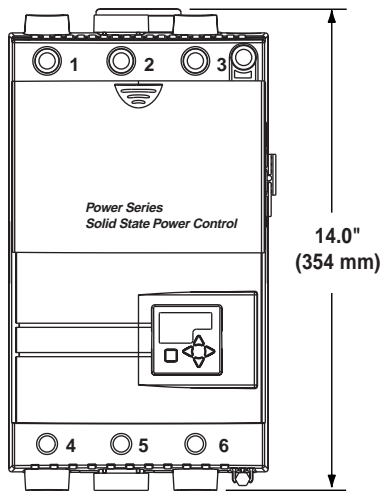

Power Series Top View

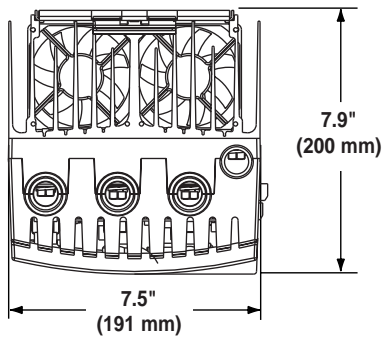

Mounting Plate Dimensions

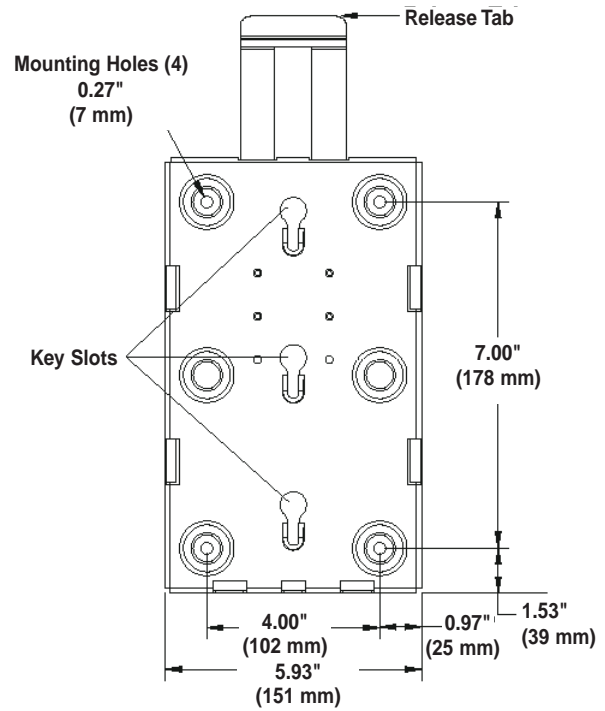

Power Series Features

Removable Mounting Plate
Power Series snaps on a pre-mounted, removable subplate.

Terminal Cover
Electrically touch-safe package.

Fuse Cover
Slides up and down for fuse maintenance and covers the high voltage components.

Digital Programmer/Display
For controller configuration, setup, and monitoring features.

Ground Lug
Built in, designed for easy ground connections.

I/O Port
Input, retransmit output, communications, and alarms.

On-Board Fan
A fan is integrated into the package on forced air cooled models to eliminate separate power connection for fan.

Allen Wrench
Used to torque terminals 1 to 6 and ground lug.

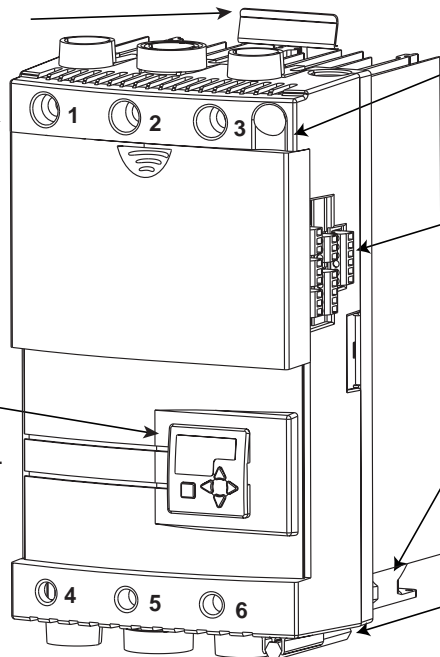

Ordering Information—1876

Power Series

Microprocessor-based
solid state power controller

Package Style

C = 65 to 250 amps

Phase

- 1 = 1-phase
- 2 = 3-phase/2 leg control, (4 SCRs)
- 3 = 3-phase/3 leg control, (6 SCRs)
- 4 = 3-phase/4 wire, wye
connected load
- 8 = 2-single-phase zones
- 9 = 3-single-phase zones

Heater Diagnostics

- 0 = None
- 1 = Heater diagnostics (required for any
heater current monitoring or current
limiting.)

Output Amperage Rating

(See Amperage Chart to the right)

Output Voltage Rating

- A = 24 to 120V
- B = 200 to 480V
- C = 200 to 600V

Communications

- 0 = None
- 1 = EIA/TIA-232/485 communications,
opto-isolated (field selectable)

Feedback/Retransmit

- 0 = None
- 1 = Load current feedback (0-10V or 0-20mA scalable
retransmit output) (Must have heater
diagnostics selected)

Custom

- 00 = None
- AA = No Watlow logo with agency approval marks
- XX = Custom, consult factory for options

Single-Phase

This configuration can be purchased with any or all the features available on the Power Series. The only limitations are the features selected by the customer upon purchase. It is intended for resistive heaters, but can also be used on transformer connected loads in the phase angle firing mode.

Three-Phase, Two Leg Configuration

This configuration is intended for zero cross firing only into a stable resistive heater. Typically, a three-phase delta or ungrounded wye connected heater is used and only two of the three V~ line phases are switched. The third phase is a direct connection through a bussbar on board the Power Series. Heater current monitoring and kVA options are available via the heater diagnostics option.

Three-Phase, Three Leg Configuration

All Power Series options are available with this configuration. It will work well with phase angle firing into a three-phase, three-wire wye or delta connected heater. In this configuration, the more common applications are transformer connected loads with heaters requiring a soft start and/or current limiting. The three-phase, four-wire configuration is intended for zero cross firing into a three-phase grounded wye/star heater **(This is a separate hardware option, model number dependent).**

Single-Phase, Multizone Configuration

This configuration is available in two and three single-phase zones and all of the features of a single-phase unit are available. (Note that there is only one alarm relay and all zones in the controller must use the same control method.)

Heater Diagnostics

Heater diagnostics may include all or only some of the features that require heater current monitoring, depending on the model selected. Heater current monitoring is only available with heater diagnostics installed on the controller. The features dependent on heater current monitoring are heater bakeout, current limiting, heater kVA monitoring, retransmit, and heater monitoring alarms such as open heater, heater out of tolerance, load balance, and shorted SCR detection/error. Heater diagnostics must also be installed if you need phase angle control with current limit.

Amperage Chart—122°F (50°C)

Non-Fan Cooled

Single-Phase		2 Zone and 3-Phase, 2 Leg		3 Zone and 3-Phase, 3 Leg	
Code	Amperage	Code	Amperage	Code	Amperage
N20	100A	N20	80A	N20	65A
N25	140A	N25	105A	N25	85A
N30	165A	N30	120A	N30	105A

Fan Cooled

Single-Phase		3-Phase, 2 Leg		3-Phase, 3 Leg	
Code	Amperage	Code	Amperage	Code	Amperage
F20	125A	F20	120A	F20	90A
F25	200A	F25	160A	F25	140A
F30	250A	F30	185A	F30	155A